



THE DYNAMICS OF A VIBROMACHINE WITH PARAMETRIC EXCITATION

V. N. BELOVODSKY

*Department of Mathematics, Donetsk State Technical University, 58 Artyoma Street,
Donetsk, UA-83000, Ukraine*

AND

S. L. TSYFANSKY AND V. I. BERESNEVICH

*Research Laboratory "Nonlinear Phenomena of Vibrating Systems", Institute of Mechanics, Riga
Technical University, 1 Kalku Street, Riga LV-1658, Latvia. E-mail: vitalijs.beresnevics@rtu.lv*

(Received 22 March 2001, and in final form 10 September 2001)

The dynamics of a vibration machine with piecewise linear elastic ties under parametric harmonic excitation is investigated. Different designs of elastic elements with periodically time-varying elasticity are described. Specific non-linear features of parametric oscillations in the system under study are revealed (the invariance of parametric vibration regime to possible disturbance of phase co-ordinates, conditions of limitedness of amplitude of parametric vibrations, spectral features of non-linear parametric regimes, etc.). By the utilization of these non-linear effects, a procedure for the design of the main parameters of a parametric vibromachine is proposed.

© 2002 Elsevier Science Ltd. All rights reserved.

1. INTRODUCTION

At present, four main methods of vibration excitation in mechanical systems are known: excitation with the aid of external force, kinematic excitation, self-excitation and parametric excitation [1]. Of these four excitation methods, only the parametric one is not widely used in vibration engineering. From the authors' point of view the reasons for such situation may be the following.

Evidently, due to the unlimited rise of amplitude of parametric oscillations, even in dissipative systems (this is predicted by linear theory [2, 3]), the possibility of the practical application of parametric resonance in vibromachines with linear elastic and dissipative ties was ruled out. In other examples, numerous publications concerned with the dynamic analysis of non-linear parametric vibrations (e.g., see references [2–7]) are not carried to practical applications. The reliable designs of structural machine members, in which elasticity or mass may periodically change with time, have not been developed. Conventionally, in mechanics, parametric resonance is considered as a negative phenomenon, which must be controlled. In mechanical engineering, this situation exists despite the fact that properties of parametric oscillations are widely used in radio, computer and laser engineering [8].

This paper presents some new results in the field of non-linear parametric oscillations, which may be of significant importance in designing technological vibromachines with parametric excitation.

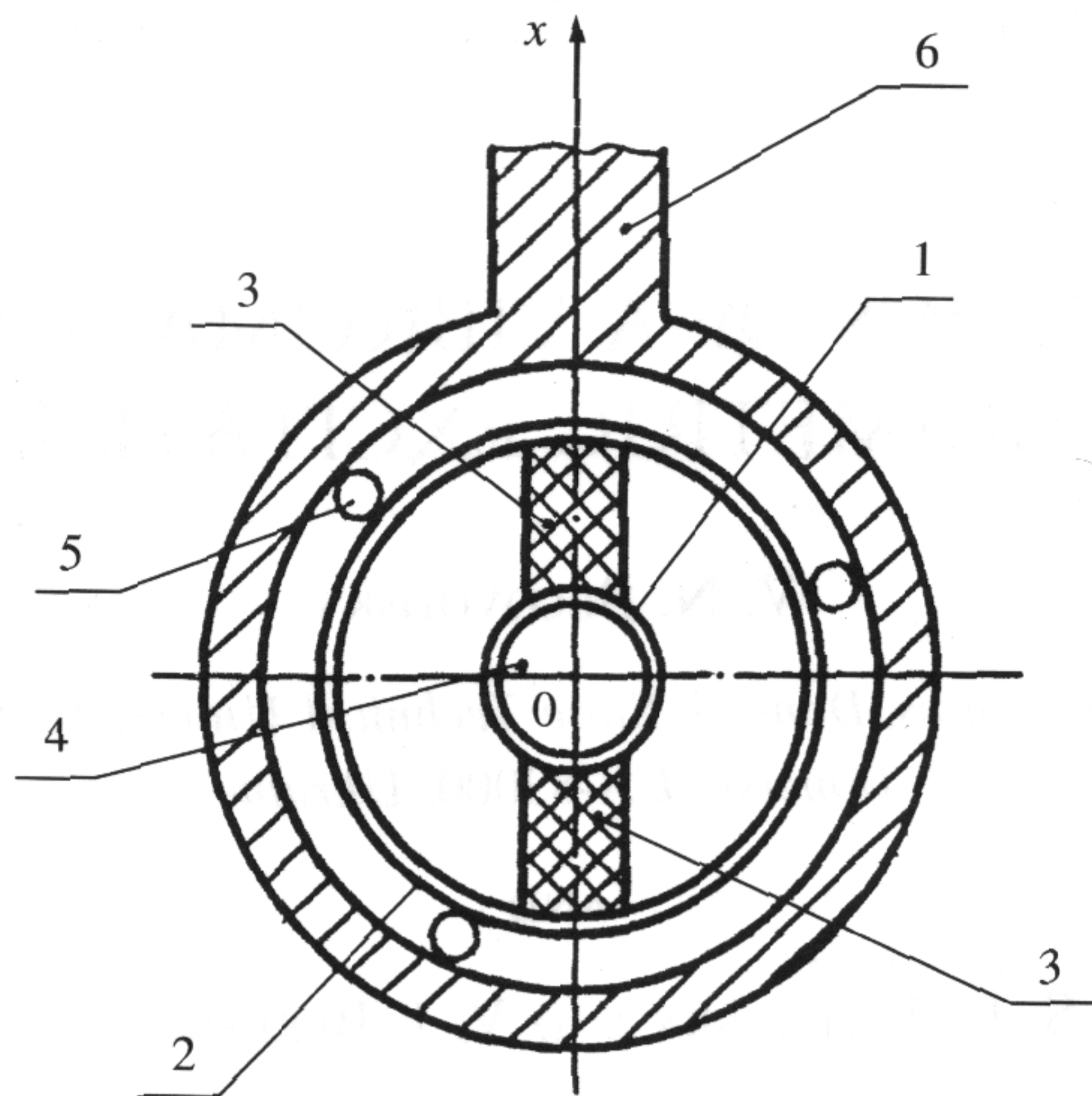

Figure 1. Schematic of the parametric elastic element in the form of a rotating disk: 1 and 2, internal and external rigid rings; 3, elastic elements (springs); 4, rigid solid shaft; 5, bearings; 6, working head of vibromachine.

2. DESIGNS OF ELASTIC ELEMENTS WITH PERIODICALLY TIME-VARYING ELASTICITY

During the development of vibromachines with parametric excitation, different designs of mechanical elements with periodically time-varying elasticity have been considered.

Parametric vibration devices, elastic elements of which can be made as flexible bars, are structurally simpler. Periodic change in time of a bar's elasticity is achieved by varying its length or through a periodic axial compression force on the bar. Different designs of parametric elastic elements of such type have been proposed [2, 9, 10]. The common demerit of all these designs lies in their great dimensions and mass.

More compact and reliable in design are parametric vibration devices with rotating elastic elements. An elementary example may be a rotating assembled shaft, parts of which are connected to each other by special couplings with anisotropic elastic characteristics [9, 11]. But this parametric elastic element affords rather small values of the elasticity ripple factor (of the order of 0.05–0.10 dimensionless units and under).

Sufficient rise of non-dimensional amplitude of parametric excitation is achieved in another design of parametric elastic element made in the form of a rotating disk (Figure 1) [9, 12]. This disk consists of two rings, 1 and 2, connected one with another by elastic elements (springs 3). Internal ring 1 is slipped over on a rigid solid shaft 4, but external ring 2, through balls 5, is connected with the working head, 6, of the vibromachine. Upon rotation of shaft 4 the elasticity of the disk in the radial direction is periodically changed, and as a result, parametric vibrations of working head 6 are excited. This design of time-varying elastic element, due to its reliability and high achievable values of ripple factor, has been used as a basis for developing a vibromachine with parametric excitation.

Parametric excitation may also be realized by pneumatic elastic elements with variable air pressure. The advantage of such a design lies in the possibility of increasing the rated load of a vibromachine. A specific example of a pneumatic parametric vibroexciter is presented in reference [9]. Besides, this book presents some other designs of mechanical elements with periodically time-varying elasticity.

At present, the mechatronics systems offer other possibilities for practical realization of parametric excitation [13, 14].

3. MATHEMATICAL MODEL

The vibromachine model to be analyzed is a single-degree-of-freedom vibratory system (Figure 2). As a parametric vibroexciter, a rotatable elastic disk with anisotropic elastic characteristic is used (see Figure 1). With rotation of elastic disk with angular velocity Ω the stiffness coefficient of the system in the x direction varies as

$$k(t) = k_0 (1 + \mu_1 \sin \Omega t).$$

An indispensable condition of the normal operation and longevity of vibromachines with parametric excitation requires a special system for limitation of amplitude of parametric oscillations. Such a limitation is necessary because under parametric excitation (unlike forced) linear damping cannot prevent an unlimited rise of the amplitude of vibrations, creating dangerous build-up. Limitation of the amplitude of parametric vibrations may be achieved by non-linear damping. But parameters of non-linear damping are difficult to control during the operation of the vibromachine, and therefore it is practically impossible to adjust the required value of the amplitude of parametric vibrations in this way. A more convenient method for simultaneous limitation and adjustment of the parametric vibration amplitudes, is to insert additional elastic limiters into the structure to create non-linear elastic ties. This method of amplitude limitation is considered in this paper.

In forming a mathematical model of the vibromachine some assumptions are made: working head is considered as a perfectly rigid body; driving motor as ideal; damping in elastic supports as viscous and it is also assumed that the elastic supports 3 (see Figure 1) are not deformed when the machine is in static equilibrium.

Under these assumptions, the differential equation of vibrations of the working head of the vibromachine can be represented as

$$m \frac{d^2 x}{dt^2} + b(x) \frac{dx}{dt} + b(1 + \mu_1 \sin \Omega t) \frac{dx}{dt} + F_r(x) + k_0(1 + \mu_1 \sin \Omega t) = 0, \quad (1)$$

where x is the co-ordinate of the working head, m is the mass of the working head, $b(x)$ is the non-linear function describing damping in the main and additional elastic supports, b is the damping coefficient of the parametric elastic element, $F_r(x)$ is the non-linear function describing the elastic characteristic of the supports, k_0 is the average stiffness coefficient of the parametric elastic element, μ_1 is the non-dimensional amplitude of the parametric excitation, Ω is the frequency of the parametric excitation.

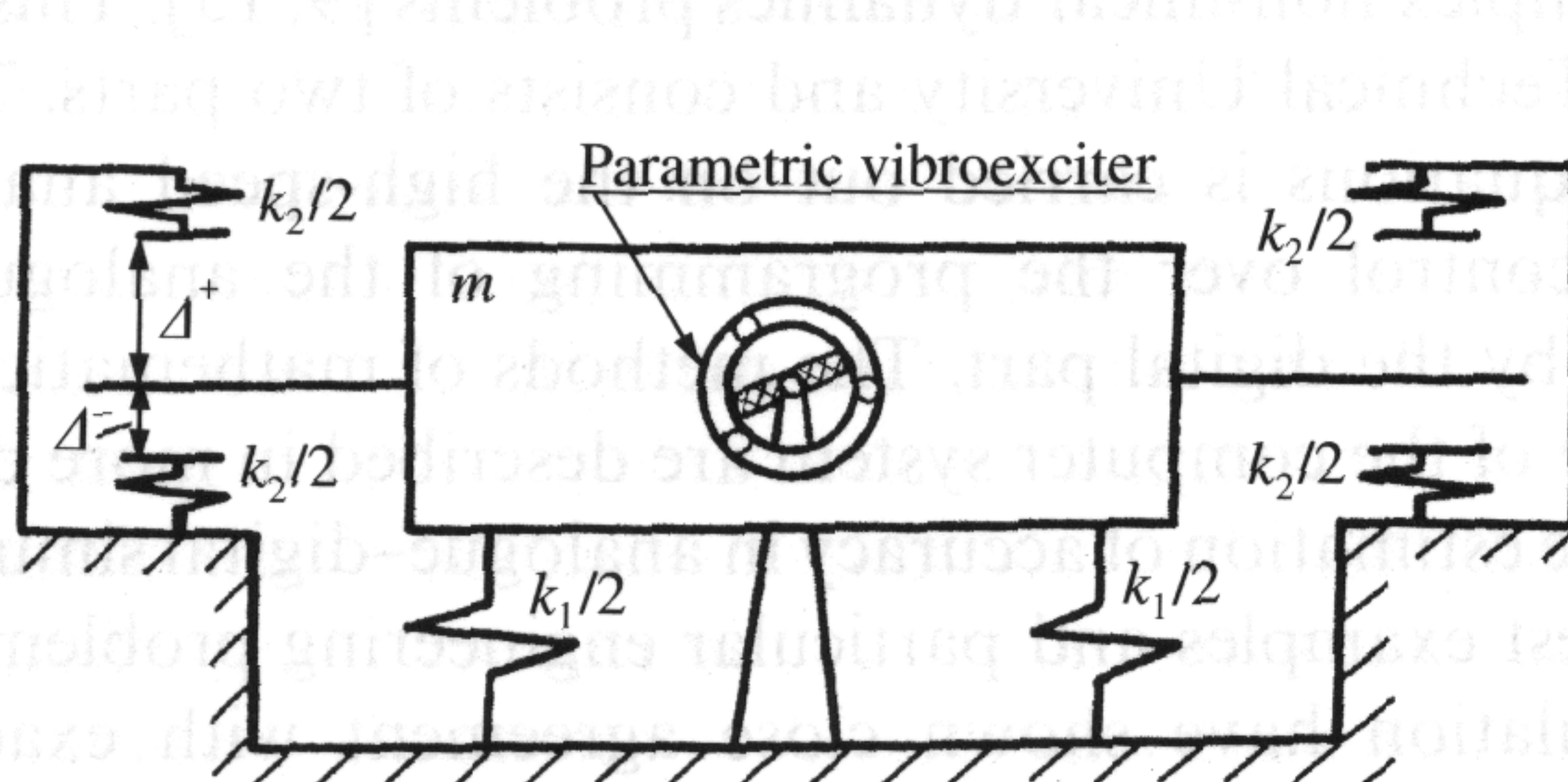

Figure 2. Vibromachine model considered in the dynamic analysis.

It is supposed that coefficient b is directly proportional to the stiffness coefficient k_0 [1]. Therefore, the internal friction force $F_b(t)$ and the elastic force $F_k(t)$ of the parametric element are described in equation (1) by the similar mathematical expressions $F_b(t) = b(1 + \mu_1 \sin \Omega t) (dx/dt)$ and $F_k(t) = k_0(1 + \mu_1 \sin \Omega t)x$.

Functions $b(x)$ and $F_r(x)$ in equation (1) can be expressed as

$$b(x) = \begin{cases} b_1(k_1 + k_2)/k_1, & x \geq \Delta^+ \\ b_1, & -\Delta^- < x < \Delta^+ \\ b_1(k_1 + k_2)/k_1, & x \leq -\Delta^- \end{cases}, \quad (2)$$

$$F_r(x) = \begin{cases} (k_1 + k_2)x - k_2\Delta^+, & x \geq \Delta^+ \\ k_1x, & -\Delta^- < x < \Delta^+ \\ (k_1 + k_2)/x + k_2\Delta^-, & x \leq -\Delta^- \end{cases}, \quad (3)$$

where k_1 is the stiffness coefficient of the main elastic supports, k_2 is the stiffness coefficient of the elastic limiters, Δ^+ and Δ^- are the initial clearances between the working head and the elastic limiters.

By the substitution $y = x/\Delta^-$ and $\tau = \omega_0 t = (\sqrt{(k_1 + k_2)/m}) t$, equation (1) and functions (2, 3) can be transformed into the more manageable dimensionless form

$$\frac{d^2 y}{d\tau^2} + \beta(y) \frac{dy}{d\tau} + \beta(1 + \mu \sin \eta\tau) \frac{dy}{d\tau} + (\mu \sin \eta\tau) y + f_r(y) = 0, \quad (4)$$

where

$$\beta(y) = \begin{cases} \beta_1(k_1 + k_2)/k_1, & y \geq \Delta^* \\ \beta_1, & -1 < y < \Delta^* \\ \beta_1(k_1 + k_2)/k_1, & y \leq -1 \end{cases}, \quad (5)$$

and

$$f_r(y) = \begin{cases} k^* y - (k^* - 1)\Delta^*, & y \geq \Delta^* \\ y, & -1 < y < \Delta^* \\ k^* y + (k^* - 1), & y \leq -1 \end{cases}. \quad (6)$$

The following notation is used in equations (4-6): $\eta = \Omega/\omega_0$ and $\mu = \mu_1 k_0/(k_1 + k_2)$ are the dimensionless frequency and amplitude of the parametric excitation, $k^* = (k_1 + k_2 + k_0)/(k_1 + k_0)$ is the dimensionless stiffness coefficient, $\beta = b/\sqrt{(k_1 + k_0)m}$ and $\beta_1 = b_1/\sqrt{(k_1 + k_0)m}$ are the dimensionless damping coefficients, $\Delta^* = \Delta^+/\Delta^-$ is the dimensionless clearance.

Equations (4-6) were solved on an analogue-digital computer system predominantly set up for the solution of complex non-linear dynamics problems [9, 15]. This computer system was developed in Riga Technical University and consists of two parts. The integration of non-linear differential equations is carried out on the high-speed analogue part of the computer system, but control over the programming of the analogue part and data processing are executed by the digital part. The methods of mathematical simulation and the operational principle of the computer system are described in more detail in references [15, 16]. The quantitative estimation of accuracy in analogue-digital simulation was carried out by the solution of test examples and particular engineering problems [9, 16-18]. The results of the test simulation have shown close agreement with exact and numerical solutions for systems with piecewise linear, polynomial and relay elastic-dissipative characteristic under forced and parametric excitation.

4. SPECIAL FEATURES OF NON-LINEAR PARAMETRIC OSCILLATIONS

By analyzing solutions of equations (4–6), some peculiarities of non-linear parametric oscillations are revealed. The more important of them (from the point of view of its application in vibration engineering) are considered in what follows.

4.1. THE INVARIANCE OF THE PARAMETRIC VIBRATION REGIME TO THE POSSIBLE DISTURBANCE OF PHASE CO-ORDINATES y, \dot{y}

As is known [2, 3], parametric resonance occurs over wide frequency ranges (regions of parametric instability) which fall in the vicinity of critical frequencies $\eta = 2/s$, where $s = 1, 2, 3, \dots$ is the order of the parametric resonance. As an example, Figure 3 shows the region of main parametric resonance ($s = 1$) in the plane of parameters μ and η . Within the bounds of this region, linear theory [2, 3] predicts an unlimited rise of amplitude of parametric oscillations (even in dissipative system). In the vibromachine under study, limitation of amplitudes of vibrations is achieved thanks to the presence of additional non-linear elastic elements with characteristics $F_r(x)$ and $b(x)$.

A typical amplitude–frequency characteristic (AFC) of steady-state parametric oscillations (for the case $\mu = 0.1$; $k^* = 3$; $\beta^* = \beta_1(k_1 + k_2)/k_1 = 3$; $\Delta^* = 1$; $\beta_1 = 0.05$) is shown in the same Figure 3. The quantities of half-swing of the displacements y_0 are projected as amplitudes on this AFC. The resonant curve presented may be divided into the parts ab and bc.

Part ab of the AFC corresponds to the parametric regimes realized with the system tuning on the main region of parametric instability. The domains of attraction of parametric regimes for this case ($\eta = 2$) are shown in Figure 4(a). The origin of co-ordinates ($y = 0, \dot{y} = 0$) is a saddle point (trivial solution, corresponding to the unstable rest state of the system). Two stable focal points S' and S'' correspond to two stable parametric regimes which are in antiphase and equal in amplitudes. Either parametric regime has its own

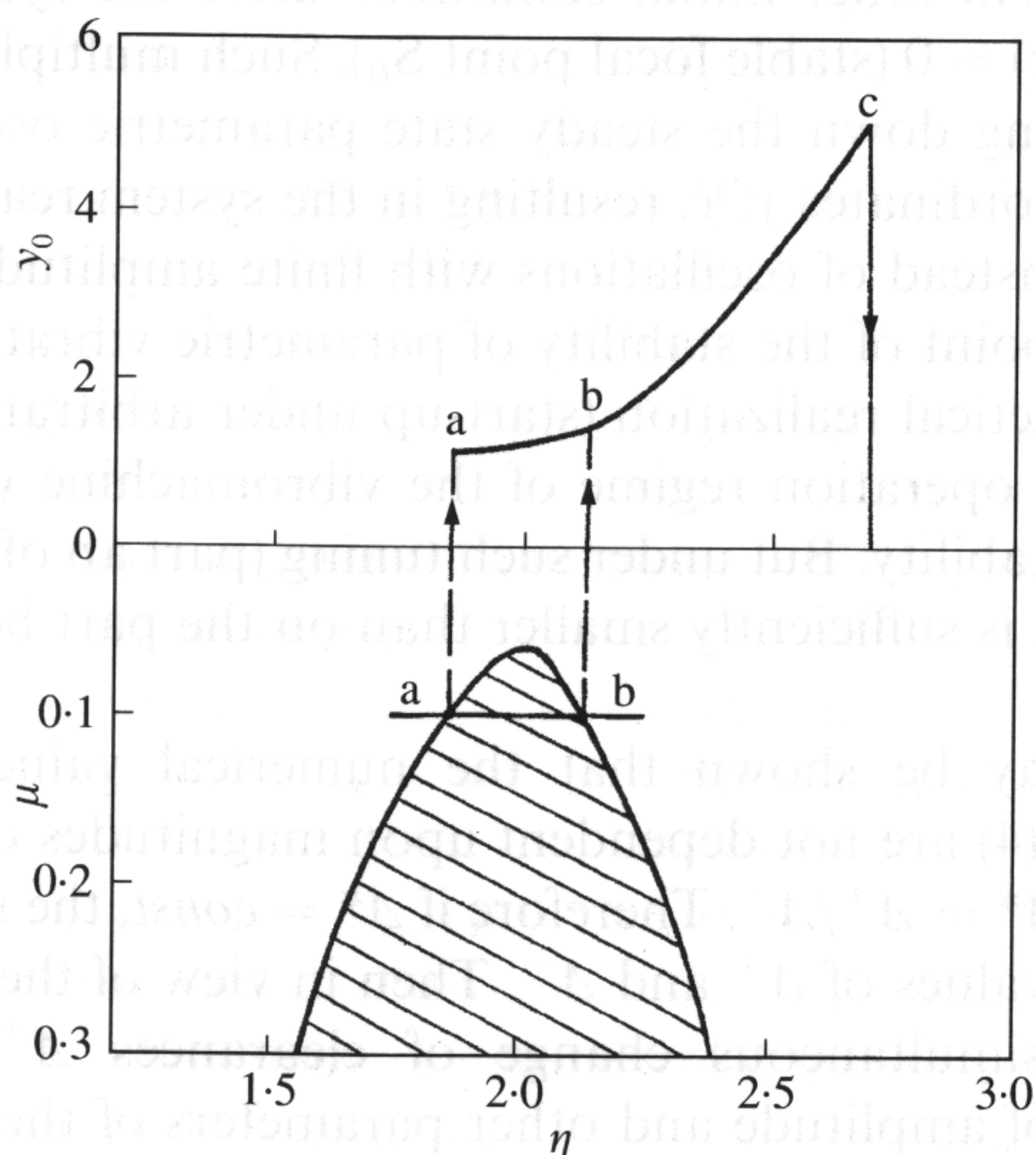

Figure 3. The main region of parametric instability and amplitude–frequency characteristic of the steady state parametric oscillations (for the case $\mu = 0.1$; $k^* = 3$; $\beta^* = \beta_1(k_1 + k_2)/k_1 = 3$; $\Delta^* = 1$; $\beta_1 = 0.05$).

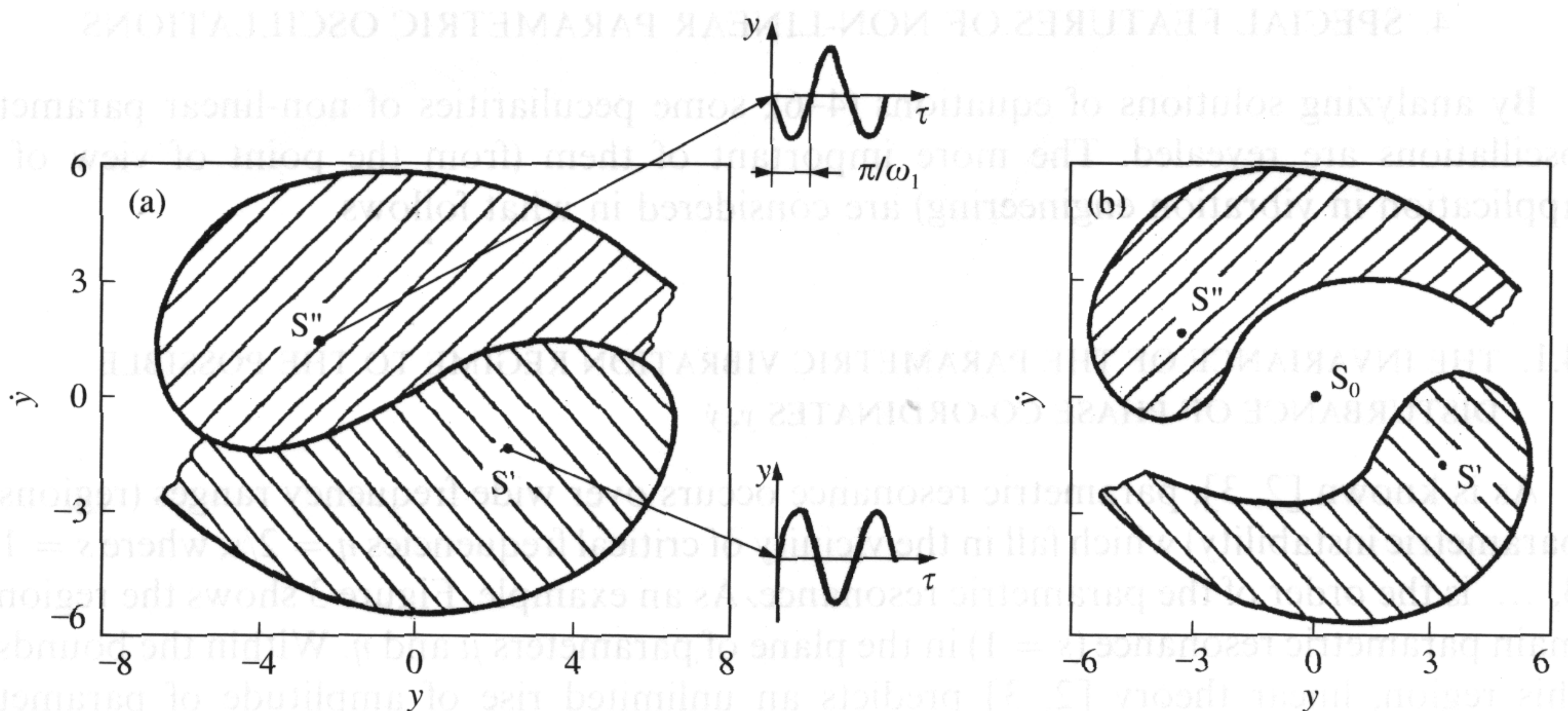

Figure 4. Diagrams of attraction regions of parametric regimes: (a) for the regimes realized inside the main region of parametric instability ($\eta = 2$); (b) for the regimes realized outside the main region of parametric instability ($\eta = 2.5$).

domain of attraction. Under some perturbation of phase co-ordinates y, \dot{y} one of these two regimes (e.g., regime S') may lose stability, but in this case instead of the regime S' the other parametric regime S'' is always excited. The amplitude and frequency of steady state parametric oscillations in both cases (regimes S' and S'') are equal. Therefore, by considering the requirements of vibration technology, regimes S' and S'' may be considered identical.

Another system behaviour is observed outside the bounds of the region of parametric instability — in the regime of non-linear pulling of vibrations (part bc of the AFC). Figure 4(b) shows the domains of attraction of parametric regimes for the case $\eta = 2.5$. There are two domains of initial conditions, which lead the system to stable parametric regimes (stable focal points S' and S''). All other initial conditions drive the system to the stable trivial solution $y(\tau) = 0$ and $\dot{y}(\tau) = 0$ (stable focal point S_0). Such multiplicity of regimes points to the possibility of breaking down the steady state parametric oscillations by an external disturbance of phase co-ordinates y, \dot{y} , resulting in the system reaching the quiescent state (stable focal point S_0), instead of oscillations with finite amplitude (regimes S', S'').

Thus, from the standpoint of the stability of parametric vibrations and considering the convenience of their practical realization (start-up under arbitrary initial conditions), it is expedient to choose the operation regime of the vibromachine within the bounds of the region of parametric instability. But under such tuning (part ab of the AFC), the amplitude of parametric vibrations is sufficiently smaller than on the part bc of the AFC (with other conditions being equal).

This being so, it may be shown that the numerical values of the coefficients of dimensionless equation (4) are not dependent upon magnitudes of clearances Δ^+ and Δ^- , but are set by the ratio $\Delta^* = \Delta^+/\Delta^-$. Therefore if $\Delta^* = const$, the solution of equation (4) is independent of specific values of Δ^+ and Δ^- . Then in view of the relationship $x = y\Delta^-$, it may be argued that simultaneous change of clearances Δ^+, Δ^- by n -fold causes a proportional change of amplitude and other parameters of the vibratory regime $x(t)$.

Hence, any vibration amplitude necessary because of technological considerations may be realized in the vibromachine operating in the region of parametric instability by adjustment of clearances Δ^+, Δ^- .

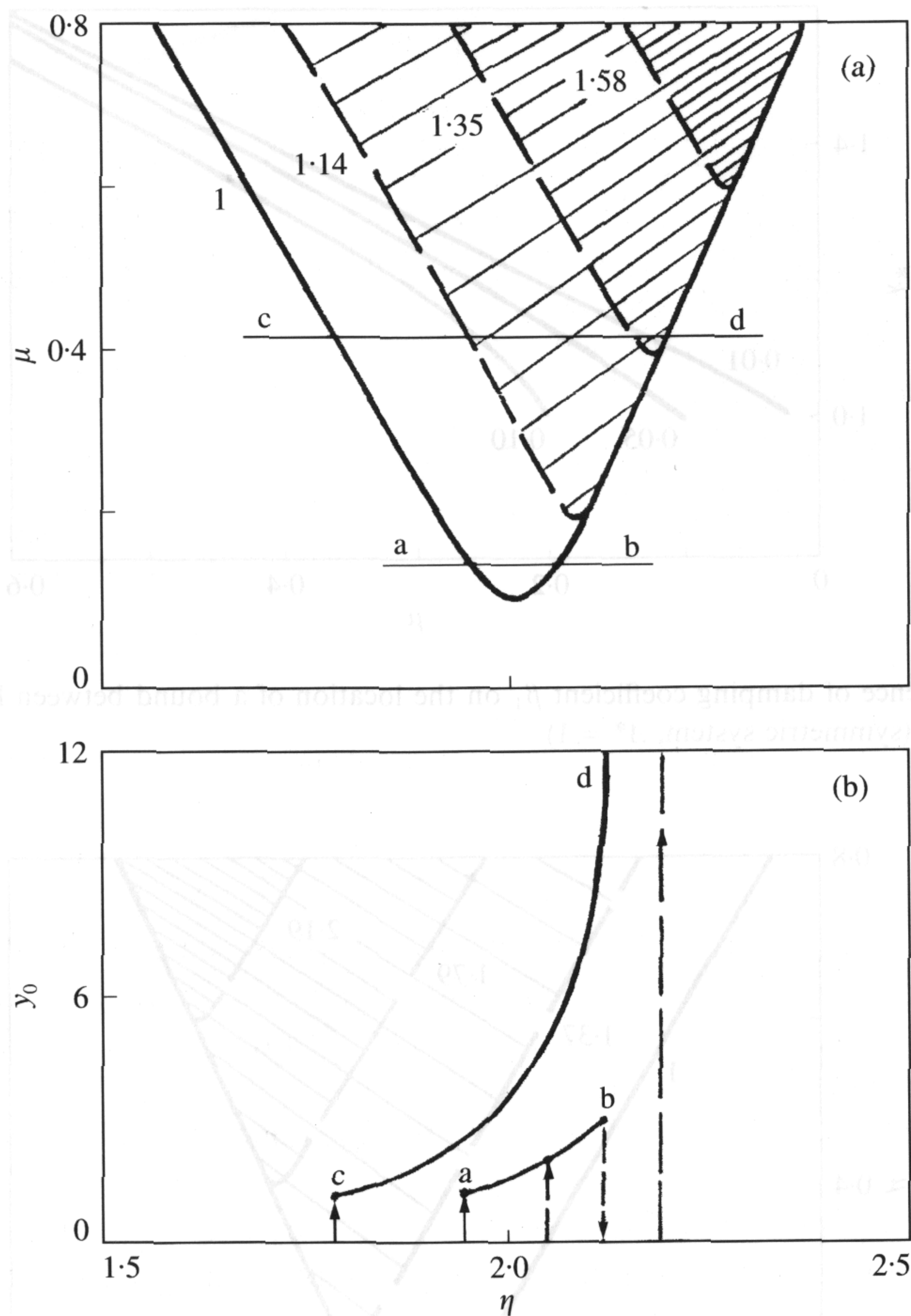

Figure 5. Zones of excitation of unlimited parametric vibrations with (a) varying k^* , ($\Delta^* = 1$, $\beta_1 = 0.05$); (b) typical resonance curves for the symmetric system ($\Delta^* = 1$, $k^* = 1.2$, $\beta_1 = 0.05$).

4.2. CONDITIONS FOR AMPLITUDE LIMITATION OF PARAMETRIC VIBRATIONS

The non-linearity of the elastic characteristic is one of the main factors having the ability to limit the amplitude of parametric vibrations. In the case of smooth elastic non-linearity of the Duffing type this condition is sufficient [2-4]. But in oscillatory systems with piecewise linear elastic characteristics studied herein, the limitation of amplitudes occurs only under specific values of dimensionless stiffness coefficient k^* and amplitude μ of parametric excitation. In order to find out the conditions for the limitation of the amplitude of parametric vibrations, the solutions of equations (4-6) corresponding to symmetric and one-sided disposition of elastic limiters are analyzed.

Figure 5(a) shows the main region of parametric instability (full line) for the symmetric system ($\Delta^* = 1$) on the co-ordinate plane μ and η . If the system is linear ($k^* = 1$), throughout this region, the unlimited rise of amplitude of parametric vibrations occurs. But in the non-linear system ($k^* > 1$), vibrations with unlimited amplitude are possible only in specific parts of the instability region (in Figure 5 these parts corresponding to various values of parameter k^* are section-lined). And what is practically important, with the increase of the parameter k^* , the dimensions of zones with unlimited vibrations are

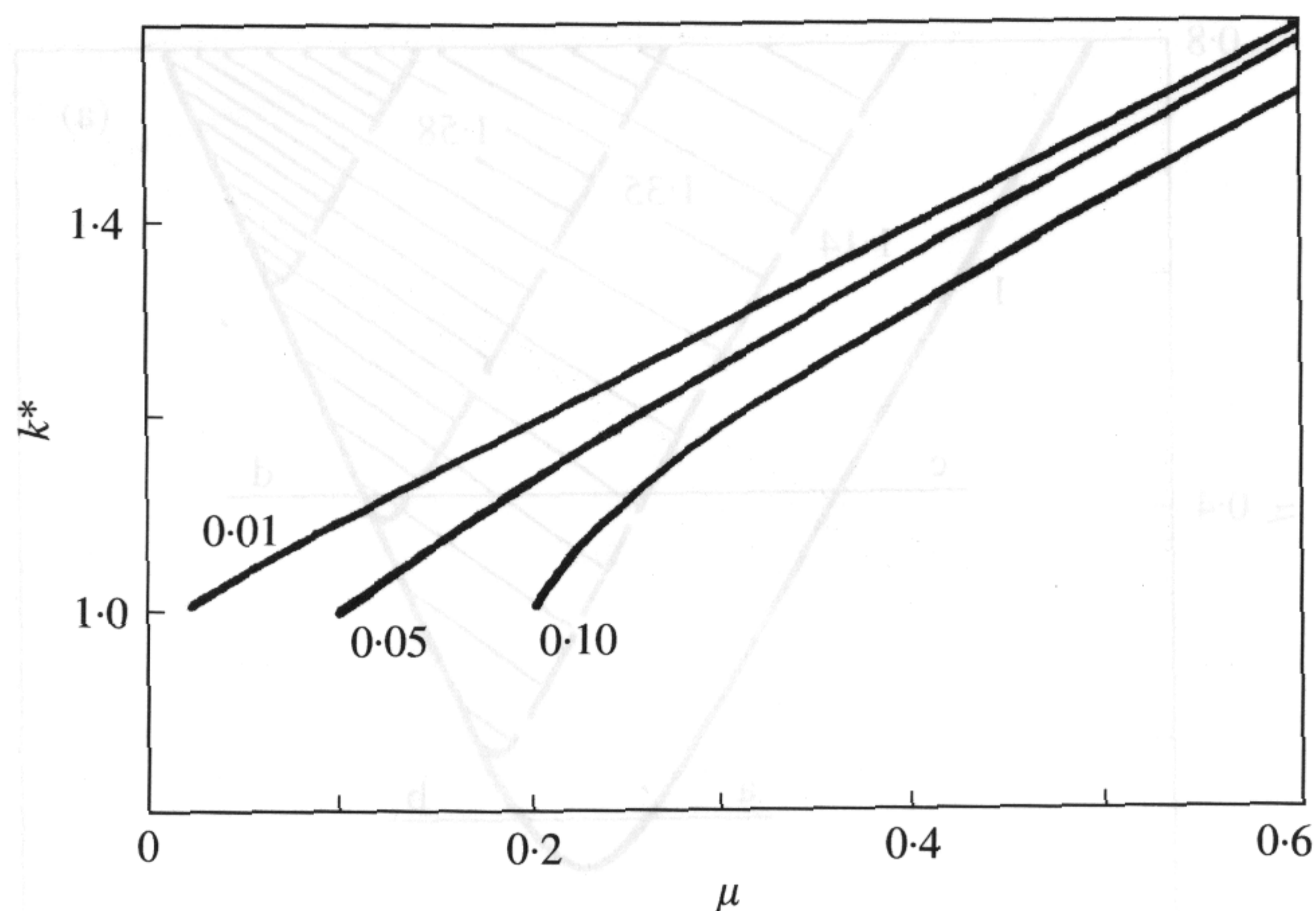

Figure 6. The influence of damping coefficient β_1 on the location of a bound between limited and unlimited parametric vibrations (symmetric system, $\Delta^* = 1$).

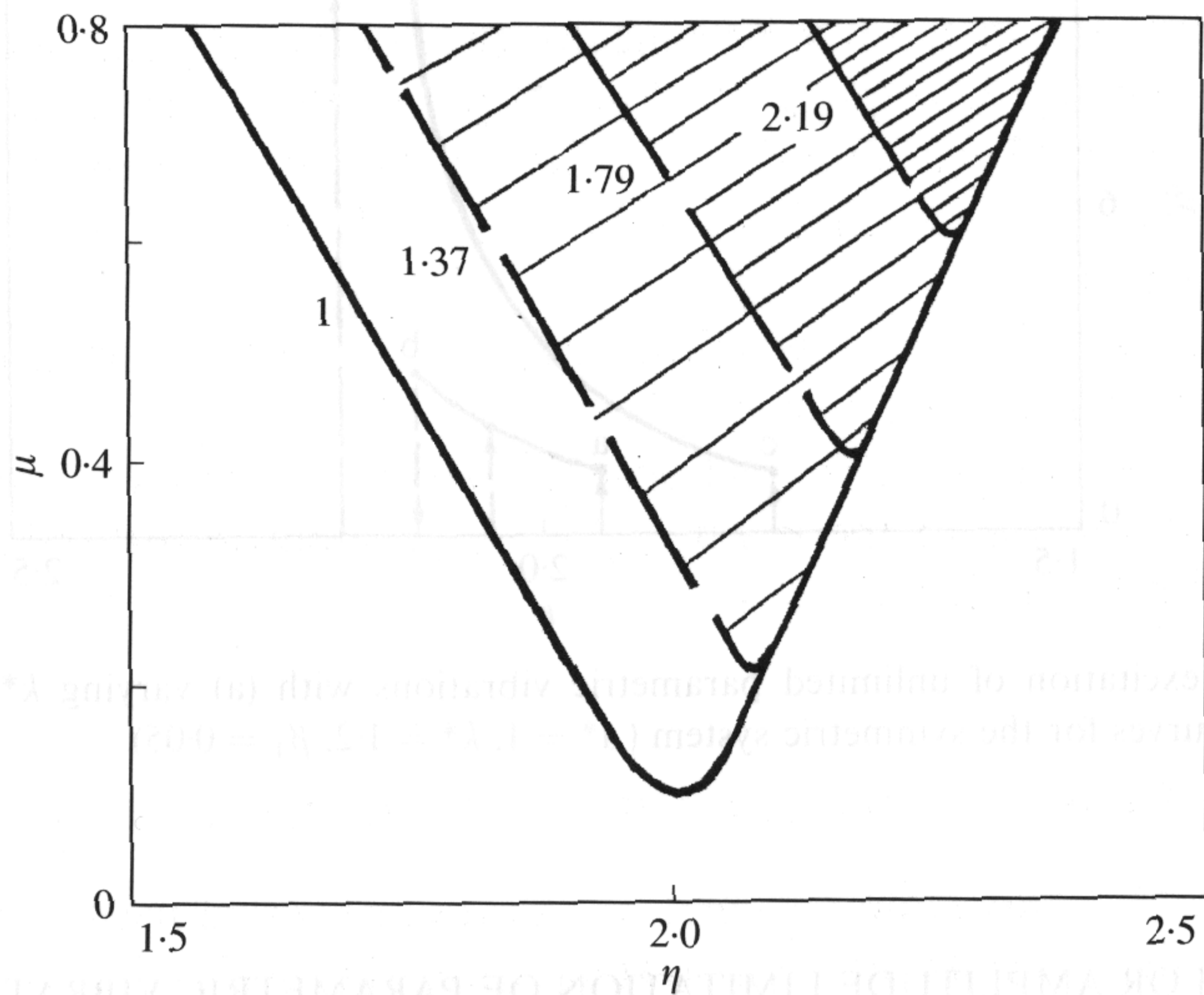

Figure 7. Zones of excitation of unlimited parametric vibrations (with varying k^*) for the system with one-sided disposition of elastic limiters ($\Delta^* = \infty$, $\beta_1 = 0.05$).

gradually reduced. Therefore, it is possible to choose the parameters k^* and μ of a vibromachine, at the design stage, to limit the amplitude of parametric vibrations.

As an example, Figure 5(b) shows the amplitude-frequency characteristics of parametric vibrations, which have been plotted for $k^* = 1.2$, $\beta_1 = 0.05$ and two different values of parameter μ (0.14, 0.42). Thus, if $k = 0.14$, the status of the system (the curve ab in Figure 5(a)) corresponds to the stable zone, therefore the amplitude of parametric vibrations is limited. On the contrary, if $\mu = 0.42$ the condition of the system is represented by the curve cd, which cuts the zone of unlimited vibrations (see Figure 5(a)). Therefore the corresponding AFC is unlimited.

The influence of damping on the conditions for limiting parametric vibrations is illustrated by three curves on the co-ordinate plane k^* and μ , corresponding to the three different values of damping coefficient β_1 (Figure 6). Actually, each of these graphs is

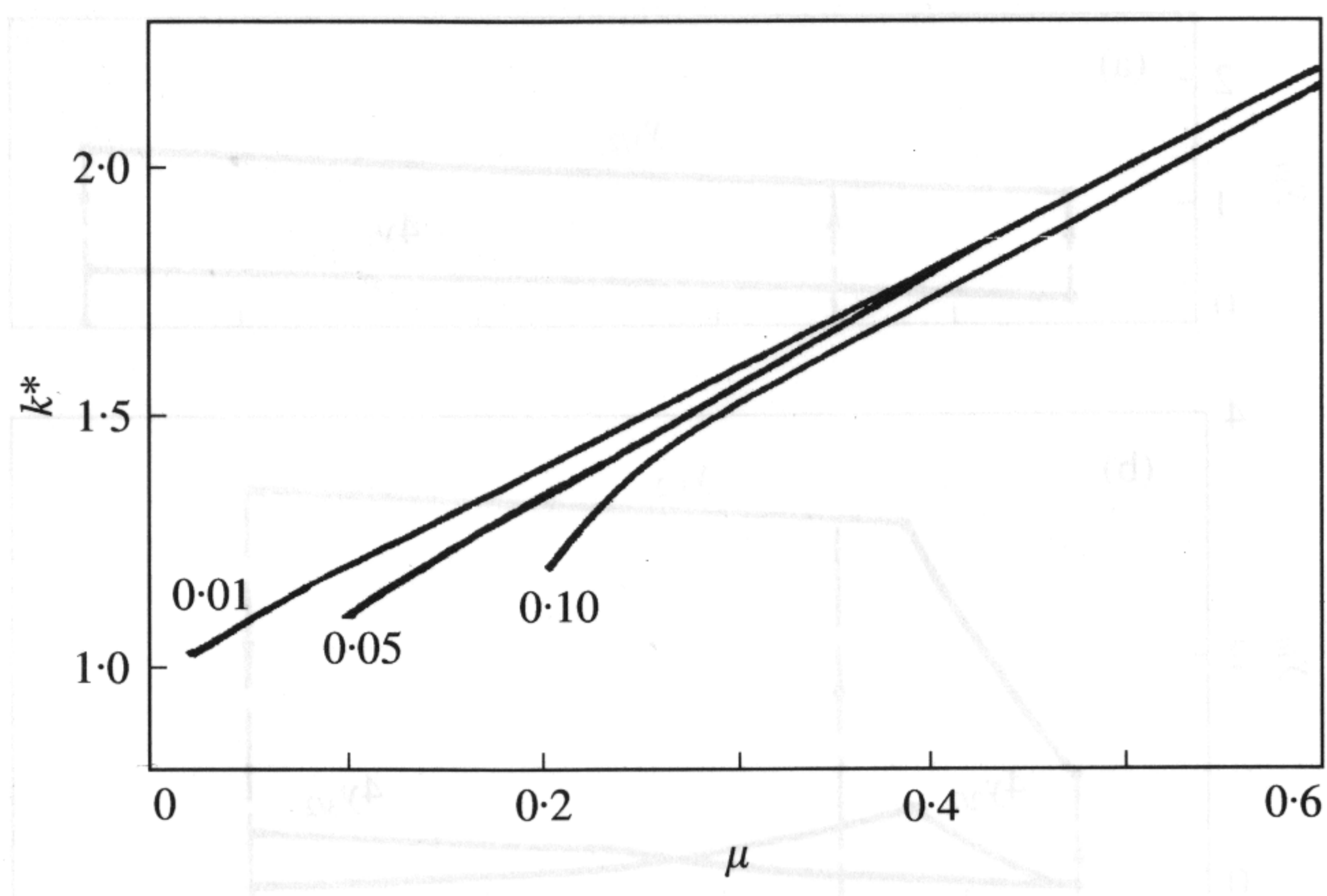

Figure 8. The influence of damping coefficient β_1 on the location of a bound between limited and unlimited parametric vibrations (one-sided disposition of elastic limiters, $\Delta^* = \infty$).

a bound between limited and unlimited solutions of equations (4–6) corresponding to the main region of parametric instability. Specifically, the domain of parameters, which lies over the graph of k^* versus μ , corresponds to limited parametric vibrations, and the domain, which lies under this graph, to unlimited vibrations. As follows from the analysis of these graphs, with the rise of the damping coefficient β_1 the domain of limited parametric solutions also increases.

At the one-sided disposition of elastic limiters ($\Delta^* = \infty$), the results are qualitatively the same and presented in Figures 7 and 8.

By using Figures 5–8, it is possible to choose the parameters of the elastic ties to minimize the amplitude of vibrations in the main region of parametric instability and this avoid a danger of build-up for a vibromachine.

4.3. SPECTRAL ANALYSIS OF PARAMETRIC VIBRATION REGIMES

Spectral features of steady state parametric vibrations excited within the main region of parametric instability ($S = 1$) are illustrated with the AFC for separate harmonic components $y_{j/i}$ (see Figure 9). These AFC have been plotted by taking into consideration only the three most intensive harmonic components and assuming the parameters of elastic non-linearity to be $k^* = 8$, symmetric and asymmetric location of elastic limiters. Numbers j/i of harmonic components denote the multiplicity of their frequencies $\eta_{j/i}$ relative to the frequency η of parametric excitation.

It is clear from the AFC presented, that for symmetric locations of the elastic limiters ($\Delta^* = 1$), the vibration spectrum has only odd-numbered harmonic components (relative to the lower harmonic of $1/2$ order). Asymmetry introduced into the elastic characteristic ($\Delta^* > 1$) leads to quantitative and qualitative changes, namely an increase in the slope of the AFC and the appearance on it of an additional bend point at amplitude $y = \Delta^*$ together with excitation and amplification of even-numbered harmonic components in vibration spectrum. It is significant, that with the increasing excitation frequency η , the amplification of even-numbered harmonics occurs when the system oscillates only on two parts (k_1 and k_2) of the elastic characteristic.

Overall, the results of the analysis show that specific values in vibration spectrum of the higher harmonic components $y_{2/2}$, $y_{3/2}$ is extremely small and doesnot exceed 5% relative to

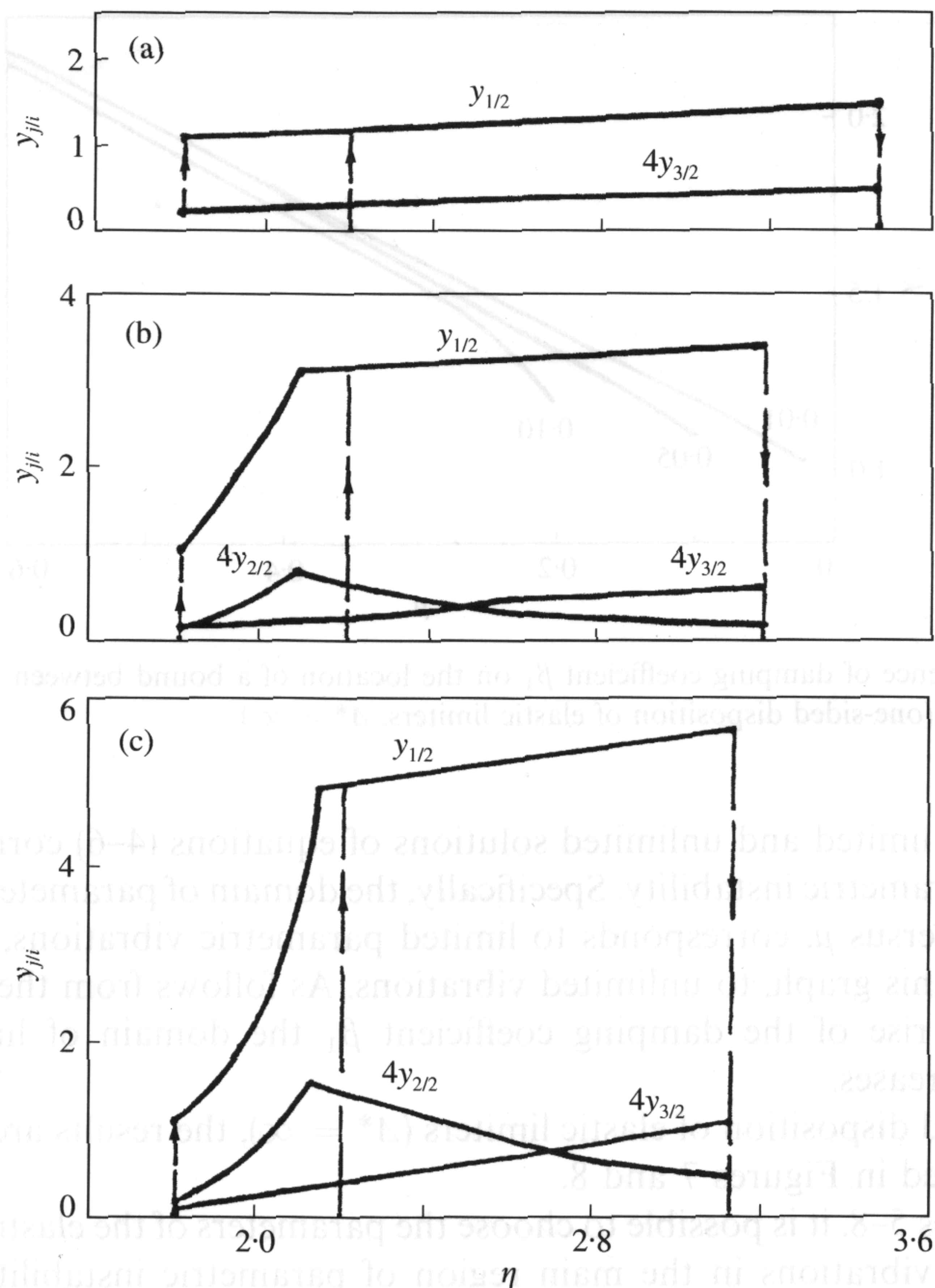

Figure 9. AFC for the separate harmonic components $y_{j/i}$ in the vibration spectrum of the parametric regimes ($\mu = 0.20$; $k^* = 8$): (a) symmetric location of elastic limiters ($\Delta^* = 1$); (b) asymmetric location of elastic limiters ($\Delta^* = 3$); (c) asymmetric location of elastic limiters ($\Delta^* = 5$).

the amplitude of fundamental harmonic $y_{1/2}$. Therefore, the oscillations may be considered as quasi-harmonic pointing to the possibility of pure frequency transformation in vibromachine with parametric excitation.

4.4. THE POSSIBILITIES OF TRANSFORMATION OF FREQUENCY SPECTRUM OF PARAMETRIC OSCILLATIONS

It is accepted in some works [2, 4], that in the main region of parametric instability the frequency of lower harmonic component in vibration spectrum is less by half in comparison with parametric excitation frequency Ω (or approximately equal to the system's natural frequency ω_0). But by the analysis of oscillatory system with asymmetric elastic characteristic ($\Delta^* \neq 1$) it was established, that in the main region of parametric instability (under specific values of systems' parameters), it is possible to excite vibrations, period T_i , which is greater by several fold in comparison with the natural period $T_0 = 2\pi/\omega_0$.

As an example, Figure 10(a) shows the domain of excitation of such low-frequency oscillations (the domain is section-lined) on the co-ordinate plane μ and η (for the case $k^* = 16$, $\Delta^* = 8$ and $\beta_1 = 0.05$). It is seen from the diagram presented, that this domain is

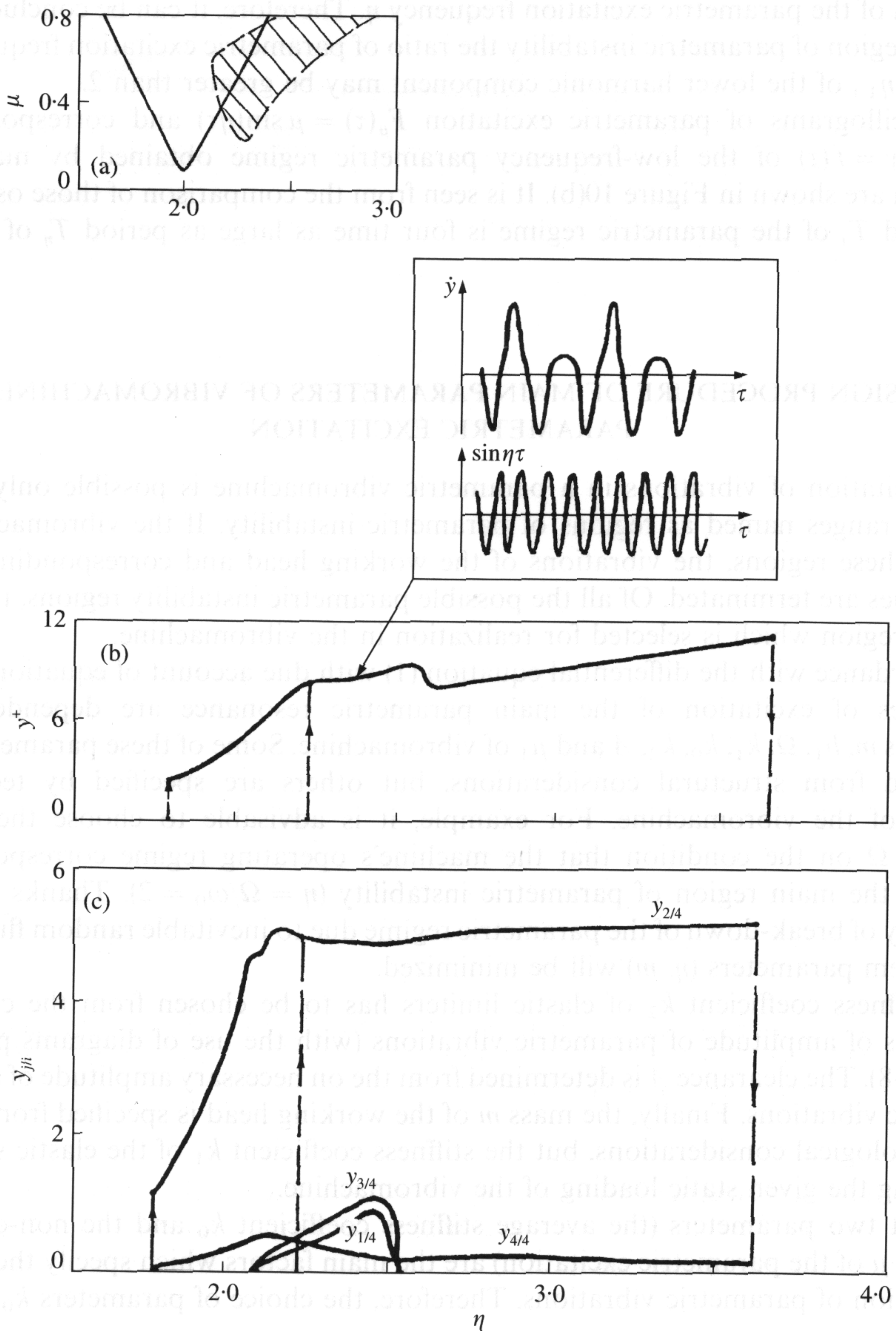

Figure 10. Transformation of frequency spectrum of parametric regimes (for the case of $k^* = 16$, $\Delta^* = 8$ and $\beta_1 = 0.05$): (a) domain of excitation of low-frequency parametric vibrations (domain is section-lined); (b) the graph of positive displacement y^+ versus frequency η (for $\mu = 0.35$); (c) AFC of predominant harmonic components $y_{j/i}$ in vibration spectrum (for $\mu = 0.35$).

sufficiently large and by its width is comparable with the main region of parametric instability.

Additionally, the graph of positive dimensionless displacement y^+ versus frequency η is shown in Figure 10(b), but in Figure 10(c) the AFC of predominant harmonic components in the vibration spectrum are presented. It is clear from these results, that excitation of parametric vibrations with high period occurs when displacement y^+ reaches the clearance Δ^+ , i.e., on condition that $y^+ \approx \Delta^+$. The frequency spectrum of these oscillations (see Figure 10(c)) contains the intensive lower harmonic component, the frequency of which is

one-fourth of the parametric excitation frequency η . Therefore, it can be concluded, that in the main region of parametric instability the ratio of parametric excitation frequency η and frequency $\eta_{1/i}$ of the lower harmonic component may be greater than 2.

The oscillograms of parametric excitation $F_\mu(\tau) = \mu \sin(\eta\tau)$ and corresponding time response $y = f(\tau)$ of the low-frequency parametric regime obtained by mathematical simulation are shown in Figure 10(b). It is seen from the comparison of those oscillograms, that period T_i of the parametric regime is four time as large as period T_η of parametric excitation.

5. DESIGN PROCEDURE OF MAIN PARAMETERS OF VIBROMACHINE WITH PARAMETRIC EXCITATION

The excitation of vibrations in a parametric vibromachine is possible only in limited frequency ranges named as regions of parametric instability. If the vibromachine is not tuned to these regions, the vibrations of the working head and corresponding vibration technologies are terminated. Of all the possible parametric instability regions, the widest is the main region which is selected for realization in the vibromachine.

In accordance with the differential equation (1) with due account of equations (2, 3), the possibilities of excitation of the main parametric resonance are dependent on the parameters $m, b_1, \Omega, k_1, k_0, k_2, \Delta$ and μ_1 of vibromachine. Some of these parameters may be determined from structural considerations, but others are specified by technological purposes of the vibromachine. For example, it is advisable to choose the excitation frequency Ω on the condition that the machine's operating regime corresponds to the middle of the main region of parametric instability ($\eta = \Omega/\omega_0 = 2$). Thanks to this, the probability of break-down of the parametric regime due to inevitable random fluctuation of some system parameters (η, m) will be minimized.

The stiffness coefficient k_2 of elastic limiters has to be chosen from the condition of limitedness of amplitude of parametric vibrations (with the use of diagrams presented in Figures 5–8). The clearance Δ is determined from the on necessary amplitude of steady state parametric vibrations. Finally, the mass m of the working head is specified from structural and technological considerations, but the stiffness coefficient k_1 of the elastic supports by considering the given static loading of the vibromachine.

The last two parameters (the average stiffness coefficient k_0 and the non-dimensional amplitude μ of the parametric excitation) are the main factors which specify the conditions for excitation of parametric vibrations. Therefore, the choice of parameters k_0 and μ is of prime importance.

The equation for determination of bounds of the main region of parametric instability is [2]

$$\eta = 2 \sqrt{1 - 0.5 \sqrt{\mu^2 - 4\beta_1^2}}. \quad (7)$$

After manipulation with equation (7) the formulas for determination of parameters k_0 and μ are

$$k_0 = m\omega_1^2 - k_1, \quad \mu = 0.25m\omega_1^2 \sqrt{64(1 + \beta_1^2) - [8 - (\Delta\Omega/\Omega)^2]^2}, \quad (8, 9)$$

where $\Delta\Omega$ is the width of the region of parametric instability and $\omega_1 = \Omega/2$.

Using the design procedure proposed, it is possible to choose the optimum parameters of parametric vibromachine.

6. CONCLUSIONS

The results presented in this paper form a theoretical basis for the development of a new generation of technological vibromachines operating on parametric resonance. The main advantages of parametric vibromachines (in comparison with traditional ones operating in regimes of forced or self-sustained vibrations) may be formulated as follows.

- (1) Exponential rise of amplitude of parametric vibrations makes it favourable to use the parametric excitation in vibromachines operating with frequent start-ups and shut-downs (e.g., in weighting vibromachines).
- (2) The vibration spectrum of parametric regimes is close to those for the monoharmonic regim (the relative value of higher harmonic components does not exceed 5–10%). It is thus possible to realize almost “pure” frequency transformation in vibromachines with parametric excitation.
- (3) The invariance of steady state parametric vibrations to possible disturbances of phase co-ordinates creates the absolute stability of the parametric regime in a vibromachine. It is especially important for the vibromachines operating under frequent external stimuli and impacts.
- (4) The amplitude of steady state parametric vibrations may be changed over a wide range by the adjustment of clearances Δ^+ , Δ^- between the elastic limiters and the working head of vibromachines.

REFERENCES

1. E. E. LAVENDEL (editor) 1981 *Vibrations in Engineering: Handbook*, Vol. 4 (in Russian). Moscow: Mashinostroyeniye.
2. V. V. BOLOTIN 1964 *The Dynamic Stability of Elastic Systems*. San-Francisco: Holden-Day.
3. M. CARTMELL 1990 *Introduction to Linear, Parametric and Nonlinear Vibrations*. London: Chapman & Hall.
4. G. SCHMIDT 1975 *Parametererregte Schwingungen*. Berlin: VEB Deutscher Verlag der Wissenschaften.
5. G. SCHMIDT and A. TONDL 1986 *Non-Linear Vibrations*. Cambridge: Cambridge University Press.
6. R. SVOBODA, A. TONDL and F. VERHULST 1994 *International Journal of Non-Linear Mechanics* **29**, 225–232. Autoparametric resonance by coupling of linear and non-linear systems.
7. M. RUIJGROK and F. VERHULST 1996 *Progress in Nonlinear Differential Equations and Their Applications* **19**, 279–298. Parametric and autoparametric resonance.
8. F. P. ZHARKOV and V. A. SOKOLOV 1976 *Circuits with Varying Parameters* (in Russian). Moscow: Energiya.
9. S. L. TSYFANSKY, V. I. BERESNEVICH and A. B. OKS 1991 *Nonlinear and Parametric Oscillations of Technological Vibromachines* (in Russian). Riga: Zinatne.
10. S. L. TSYFANSKY, V. I. BERESNEVICH and V. M. OZHIGANOV 1981 U.S.S.R. *Author Certificate (Patent) No. 880506*. Parametric vibration exciter.
11. S. L. TSYFANSKY, V. I. BERESNEVICH and V. M. OZHIGANOV 1981 U.S.S.R. *Author Certificate (Patent) No. 845866*. Drive of vibration machine.
12. S. L. TSYFANSKY and V. N. BELOVODSKY 1983 U.S.S.R. *Author Certificate (Patent) No. 1036394*. Parametric vibration exciter.
13. P. R. PAGILLA, B. YU and K. L. PAU 2000 *IEEE/American Society of Mechanical Engineers Transactions on Mechatronics* **5**, 410–418. Adaptive control of time-varying mechanical systems: analysis and experiments.
14. H. M. J. VAN BRUSSEL 1996 *IEEE/American Society of Mechanical Engineers Transactions on Mechatronics* **1**, 127–136. Mechatronics—a powerful concurrent engineering framework.
15. S. TSYFANSKY and V. BERESNEVICH 1996 *Proceedings of the 5th International Conference of Cranes and Textile Machines. Gdansk, Poland*, 257–260. Mathematical simulation of dynamics of textile machines on specialized analog-digital computational complex.

16. S. L. TSYFANSKY 1979 *Electric Simulation of Oscillations in Complex Nonlinear Mechanical Systems* (in Russian). Riga: Zinatne.
17. S. L. TSYFANSKY and V. I. BERESNEVICH 1997 *Journal of Sound and Vibration* **203**, 495–503. The control of the operating condition of a subharmonic vibromachine.
18. S. L. TSYFANSKY and V. I. BERESNEVICH 1998 *Journal of Sound and Vibration* **213**, 159–168. Detection of fatigue cracks in flexible geometrically non-linear bars by vibration monitoring.

REFERENCES

1. E. E. LAVINDEL (editor) 1981 *Vibration in Engineering*. Handbook Vol. 4 (in Russian). Moscow: Mashinostroyeniye.
2. V. I. BERESNEVICH 1991 *The Dynamic Stability of Elastic Systems*. San Francisco: Holden-Day.
3. V. I. BERESNEVICH 1990 *Introduction to Linear, Parametric and Nonlinear Vibrations*. London: Chapman & Hall.
4. G. SCHMIDT 1975 *Parametrische Schwingungen*. Berlin: VEB Deutscher Verlag der Wissenschaften.
5. S. L. TSYFANSKY and V. I. BERESNEVICH 1986 *Non-Linear Vibrations*. Cambridge: Cambridge University Press.
6. R. SVOBODA, A. FOND and J. VEKUNST 1994 *International Journal of Non-Linear Mechanics* **29**, 225–232. Autoparametric resonance by coupling of linear and non-linear systems.
7. M. RUDROK and F. VEKUNST 1996 *Progress in Nonlinear Differential Equations and Their Applications* **19**, 235–252. Parametric and autoparametric resonance.
8. I. P. NIKOLAYEV and V. I. BERESNEVICH 1976 *in* *in* with V. I. BERESNEVICH (in Russian). Moscow: Energiya.
9. S. L. TSYFANSKY, V. I. BERESNEVICH and A. B. ORS 1991 *Nonlinear and Parametric Oscillations in Technological Vibromachines* (in Russian). Riga: Zinatne.
10. S. L. TSYFANSKY, V. I. BERESNEVICH and V. M. OZHIGONOV 1981 *U.S.S.R. Author Certificate* (Patent No. 28096). Parametric vibration exciter.
11. S. L. TSYFANSKY, V. I. BERESNEVICH and V. M. OZHIGONOV 1981 *U.S.S.R. Author Certificate* (Patent No. 84706). Drive of vibration machine.
12. S. L. TSYFANSKY and V. N. BELOVODSKY 1983 *U.S.S.R. Author Certificate* (Patent No. 1036304). Parametric vibration exciter.
13. P. R. PAGLIA, B. YU and K. L. PAO 2000 *IEEE American Society of Mechanical Engineers Transactions on Mechatronics* **2**, 410–418. Adaptive control of time-varying mechanical systems: analysis and experiments.
14. H. M. J. VAN BRUSSEL 1996 *IEEE American Society of Mechanical Engineers Transactions on Mechatronics* **1**, 137–156. Mechatronics – a powerful concurrent engineering framework.
15. S. TSYFANSKY and V. BERESNEVICH 1996 *Proceedings of the 5th International Conference on Coupled and Textile Machines*. Gdansk, Poland, 257–260. Mathematical simulation of dynamics of textile machines on specialized analog-digital computational complex.