



International Journal of Innovative and Information Manufacturing Technologies, SHEI "Donetsk National Technical University"; 58, Artyoma Street, 83001 Donetsk, Tel.: +38 062 305 01 04, Fax: +38 062 301 08 05, E-mail: [tm@mech.dgtu.donetsk.ua](mailto:tm@mech.dgtu.donetsk.ua), <http://iimt.donntu.edu.ua>

## DESIGNING OF TECHNOLOGICAL MODULES ASSEMBLAGE

GRIGORIEVA Natalia

Department of Mechanical Engineering technology,  
Lutsk National Technical University; Lvov's str. 75, 43018, Lutsk, UKRAINE.  
*Corresponding author: Grigorieva Natalia: E-mail: vik\_shabajkin@ukr.net*

*Submitted: 15.05.2015; accepted 25.05.2015.*

**Abstract.** Modular assemblage processes, principles of design technology and the structure of modules that make up the processes of assembly are described. To indications of competitiveness of assembly, processes can be referred: high technical characteristics and parameters of quality of assembly and low production costs. An approach to the optimization of the practical formation of modular and assembly processes used criteria. For reach of such evaluation can use a method of a ratio of parameters of process to base variant or to conduct an evaluation on an integrated rate of competitiveness. In most cases is inherent in the first method some indeterminacy.

**Keywords:** assembly, module, processes, technology.

### 1. Introduction

On designing of modular assembly technology have an influence: special and own structure of modular technology, technological possibilities of assembly equipments, degree of concentration technology, levels of automation and adaptability to manufacture of a construction object of assembly and other [1]. The process of designing such technology can be represented as selection of a subset of assembly movements from sets of modular technology, possibilities of the robot and requests of assembly. For reaching an object in view it will be possible to use operations of intersection of these sets circumscribed by the equations, which are subject to optimization on selected criterions.

As that known [2], modular assembly technologies are represented by some set of the interconnected technological assembly modules enveloping main varieties of assembly works. Each module is good spent and optimized technological unit of repeated use, which the constructional module answers, on which modular technology is executed. Assembly module is understood as the completed population of main and auxiliary assembly movements (operations) executed in a demanded sequence in one working zone, in which the necessary gang of assembly tools and adaptations, i.e. technological tooling for a modification of the form and properties is indicated the object of assembly. Such assembly module is depending on a degree of concentration of technology, is for assembly of some number of assem-

bled junctions. For reach of such approach the technological modular designing can be shown to an automatic selection necessary, docked among them, modules executed in a system of automatic design of technological processes. The assembly modules should be docked as to other modules of a technological line-up of assembly process, and modules of the equipment, tooling and management. Therefore, generalized parameter joint of modules should include not only technological, also constructional and operational parameters of technologies.

The features of designing environments of modules on a comparison with simple assembly are, that for want of it is necessary to such development to take into account technological possibilities of used robots, i.e. menu of assembly and auxiliary movements, other degree of concentration of operations, levels of automation of process and adaptability to manufacture of a construction of a collected item. It is necessary to take into account also constructional and organizational features robot's of assembly. A main evaluation of efficiency modular environments of technology in the issue is the maintenance of high productivity and flexibility for reach such restrictions as an accuracy, reliability and technological production cost.

*1.1. The test objective and tasks of analysis.* The test objective and tasks of analysis. The aim of the article is necessary to ground representation of modules and modular assembly processes. The objective of the

analysis is a method of designing a modular technology in its optimization.

## 2. Statement of contents

For reach of development such technology basis, on which the designing is executed are the features of designing of automated assembly technology with program control. On these basis the designing robot's of technological and constructional modules of the assembly component an essence of modular assembly technology is executed. Such develop are well known [3] generally which brief essence consists in the following. For a realization local (route of assembly) and global (maintenance of parameters of quality for want of issue of items) purposes the techniques of ascending and descending designing are used. The ascending designing has an empirical character and uses the approach to solution of problem, unequivocal engineering solution without a comparison of possible versions absence of an economic optimality of a solution. The descending designing is based towards methods of the theory of production management and mathematical programming. It is characterized by orientation to parameters of productivity and cost, comparison of variants and maintenance of profitability of an optimum solution. Main principles of designing robots of assembly processes are: the overlapping of high efficiency and universality; the hierarchy; the primary program resetting-up; the maintenance of the greatest object closure.

It is supposed that before designing robots of assembly technology the objects of assembly are selected correctly which, in general should meet the requirements which were program of assembly, i.e. technological possibilities of the used equipment, tooling and program control. It in main restriction on a mass of collected units, their overall dimensions, number of component details (no more than 20-30 pieces), absence of flexible details or made from soft materials, significance of some parameters of quality (exactitude, productivity, cost price), character of assembly movements.

As milestones of development robot's of technological assembly process it is possible to consider: a selection of assembly units, their grouping, classification of surfaces and conjugations, analysis of adaptability to manufacture of a construction of units, unification of constructional elements, analysis and development of specifications, technological analysis of a construction, choice of methods of assembly of conjugations, maintenance of a required the exactitude, development of a route of assembly and control programs for robots, fashion assembly process for the dimensional analysis, development of technological operations, accountability.

For want of to development of technology robots of assembly the highest degree of concentration of operations is used, for which maintenance the necessary grabs, technological equipment and execution time are selected. For reach of number of items should be minimum. However upper bound of a degree of concentration of operations is the parameters of reliability and

cost of the assembly robot with technological tooling [4]. Further such elements of assembly operation as submission of details, their automatic orientation, interface, fixing, monitoring and pick up of the assembled unit in details are considered. For this purpose the necessary standard and original systems are selected. For reach that even at these stages the further improvement of a construction of collected details both units on adaptability to manufacture and correcting of groups of objects, collected on robots is conducted. As most effective are consider varied program resetting-up assembly systems of a modular construction. Final stage is the feasibility report of the designed assembly technology will be evaluation of competitiveness.

To indications of competitiveness of assembly, processes can be referred: high technical characteristics and parameters of quality of assembly and low production costs. For reach of such evaluation can use a method of a ratio of parameters of process to base variant or to conduct an evaluation on an integrated rate of competitiveness [5]. In most cases is inherent in the first method some indeterminacy. The integrated parameter of a technological level settles up as  $A_T = \sum_1^n a_i f_i$ , where

$a_i$  - weight factor  $i$  parameter have been assigned to the expert;  $n$  - number of such parameters;  $f_i$  - parametrical index. Such parameter on economic parameters is similarly determined  $A_E$ . Then the integrated rate of competitiveness assembly robots of process is determined from expression

$$A_{\oint} = A_T / A_E = \sum_1^n a_i f_i / \sum_1^n a_i^* f_i^* . \quad (1)$$

For reach of  $A_{\oint} > 1$  the assembly process exceeds analog on competitiveness and on the contrary. For reach of negative outcomes the assembly process is subject re-designing.

## 3. Shaping of assembly modules

It is possible to approach construction such modules as were specified point of view from the point of view of maximum use of technological possibilities of assembly robots, i.e. assembly movements executed by them. In a general view, such robot can be  $p$  of coordinate systems (fig.1) each of which can be executed till three linear and in which second column  $B$  describes a vector of attitudes. The total is noted of executed movements by a rectangular matrix

$$D = \begin{vmatrix} x_1 & y_1 & z_1 & \alpha_{x1} & \beta_{y1} & \xi_{z1} \\ x_2 & y_2 & z_2 & \alpha_{x2} & \beta_{y2} & \xi_{z2} \\ \cdot & \cdot & \cdot & \cdot & \cdot & \cdot \\ x_p & y_p & z_p & \alpha_{xp} & \beta_{yp} & \xi_{zp} \end{vmatrix}, \quad (2)$$

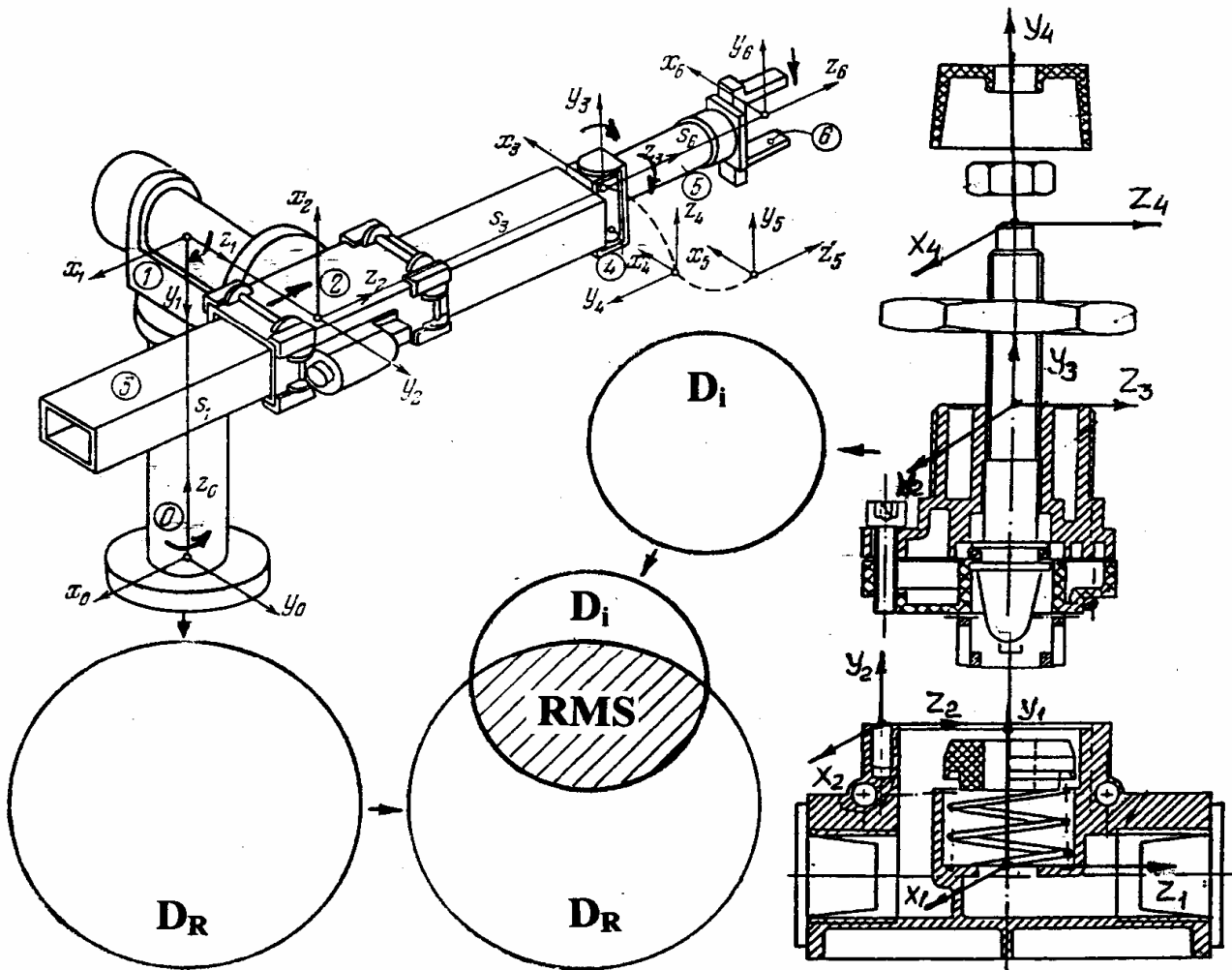

Fig. 1. Shaping of a set assembly movements of the robot and assembly unit.

there  $x_i, y_i, z_i$  – linear transitions of elements of the robot concerning coordinate;  $\alpha_{xi}, \beta_{yi}, \xi_{zi}$  – that, angular;  $p$  – number of coordinate systems of the robot. Actually, of such movements in robots the small amount is executed, so for shown on fig.1 of the robot the matrix of executed movements has a simple kind

$$D_R = \begin{pmatrix} & & & \xi_{z0} \\ & & & \xi_{z1} \\ & z_2 & & \\ & z_3 & \beta_{y3} & \xi_{z3} \\ y_6 & & & \end{pmatrix} \quad (3)$$

As the assembly, movements are executed motor-operated hand of the robot it is better to emanate from a transformation matrix  $\bar{i}^n$  of a link circumscribing it a position in an initial frame of the robot

$$S = \begin{pmatrix} (BC)_x & B_x & C_x & P_x \\ (BC)_y & B_y & C_y & P_y \\ (BC)_z & B_z & C_z & P_z \\ 0 & 0 & 0 & 1 \end{pmatrix} \quad (4)$$

orientation,  $C$  – vector of the approach and  $P$  – vector position of a point  $P_i$  motor-operated hand.

Thus in one coordinate system of the assembly robot the various movements can be executed which set can be expressed by a ratio of association

$$d_1 = x_1 \cup y_1 \cup z_1 \cup \alpha_x \cup \beta_y \cup \xi_z \cup l \cup g = \bigcup_1^a d_i, \quad (5)$$

there  $l, g$  – additional special transitions and rotations for example vibrating, discontinuous, trajectory auto search etc., indicated for a completeness of a spanning;  $a$  – their amount. Then it is possible to present the previous formulas (2,3) as

$$D_R = d_1 \cup d_2 \cup \dots \cup d_p = \bigcup_1^p d_i \quad (6)$$

i.e. each robot can be described as a system, in which there is a possibility to execute the certain linear, angular and special movements. Selection will require if some group of movements for example for analysis it also rather simply to execute in an outcome of additional operations above appropriate sets. The image of some set can be obtained with the help of circles of the Euler [2] (fig. 2).

The similar approach is applied and for reach of analysis of assembly movements of object robot's of assembly, i.e. assembly unit, that is a basis for correct installation of group of collected units on the robot and selected for this purpose. In general view the typical representative group of units also can have  $p^*$  coordinate systems (fig.1), in each of which is necessary to execute a number of linear, angular and special move-

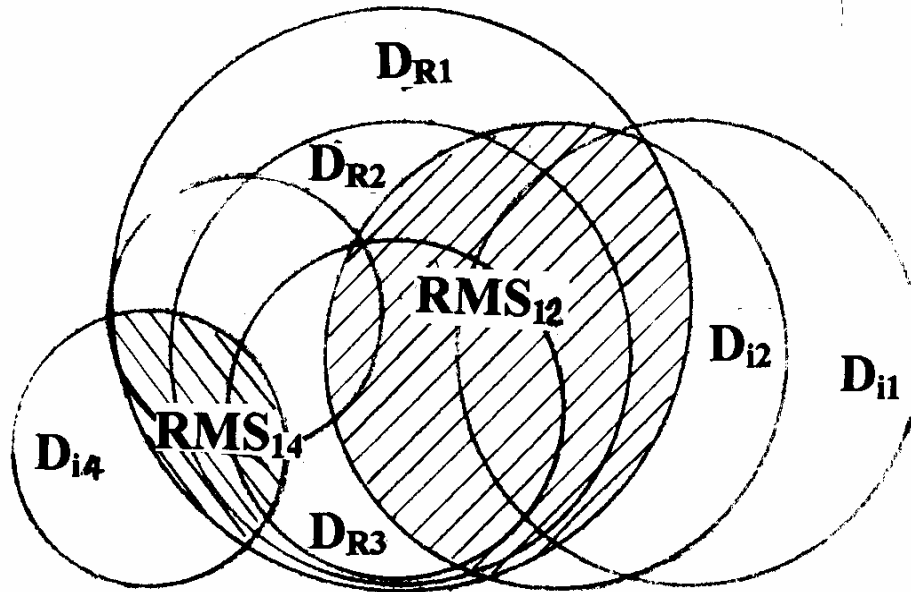

Fig.2. The product of sets assembly movements of various robots and assembly units

ments, that can be noted by similar matrices (2, 3, 4) and equations (5,6). Finally, the necessary assembly movements for a unit are noted as

$$D_j = d_1^* \cup d_2^* \cup \dots \cup d_p^* = \bigcup_1^p d_j^*, \quad (7)$$

Graphical it is represented by the circles of the Euler.

Thus, technological robot's the module of assembly process is represented as intersection of final sets of the robot and assembly unit

$$RMS = D_i \cap D_j = (d_{p1} \cup d_{p2} \cup \dots \cup d_{pk}) = \bigcup_1^k d_i, \quad (8)$$

there  $d_{pi}$  – assembly movements, which can be executed by the robot and are necessary for assembly of a unit. The executed assembly movement robot's by the module answer the shaded area of intersection of the considered sets. Technological robot's the module with the indicated assembly movements also will have maximum concentration of such movements may be will be optimum on a criterion, for example, cost costs.

The approaches to solution and this problem can be the further analysis of the indicated equations of sets. There are starting up some robots with the executed assembly movements (fig.2) which together with technological equipment are characterized by the various costs. On the other hand, there is also number of collected units requiring for assembly those or other assembly movements. As it is visible from a fig.2, the areas of intersection of the indicated sets can be rather various. The broad possibilities are opened for search of optimum solutions on various criterions. So point of view from the point of view of deriving the greatest area

of intersection for example for unit  $K_j$ , the robot  $R_l$  is most approaching for fulfillment robot's of assembly. If cost of the robot  $R_2$  will be smaller, it(he) can be selected for a realization of assembly process, but for reach of structure robot's of the module will be already other. To improve the position it will be possible expense of correcting group of units for assembly, modification of the typical representative of group etc. For this purpose the composition of objects [6], putting in the correspondence to pair of operands (robot and assembly unit) third object - composition, i.e. robots the module of assembly can be used

$$D_i \perp D_j = RMS, \quad (9)$$

There are corresponds matrix and columns of grouped and it allows rather simply to reconsider more number of objects of assembly units using known rules of the sum and product, formula of inclusion and elimination, recurrent ratio and generating function that especially it is important for a simple visual solution of this practical problem: shaping robot's of the assembly module.

#### 4. Conclusion

Technological assembly robot's modules representing a basis of modular technologies on assembly robots can be rather simply at the first stage generated on a criterion of a maximum of assembly movements. For this purpose the sets of possible assembly movements on the robot and necessary - for the typical representative of group collected units are composed with use of the theory sets. The intersection of these sets also determines a structure robot's of the module. For reach that the broad practical possibilities for the reasonable

selection of group collected units and choice of the assembly robot most answering definite conditions are opened.

### **Acknowledgement**

The author thanks Professor of the Moscow Aviation Institute Vladimira Sergejevicha Brusova for providing the results of the research process modules aircraft production.

### **References**

1. Bozhidarnik V., Grigorjeva N., Shabaykovitch V. Automatic assemblage of article: - Lutsk, „Nadstir'ya”, 2005. - 386 pp.
2. Book of reference on industrial robotics: 2 books. Translation from engl. Sh. Shofa. - M.: Mashinostroenie, 1990.-480+480 pp.
3. Machine building. Book of reference. Technology of assembling at machine building. T III- Editor J.N. Solomencev. - M.: Mashinostroenie, 2001.-640 p.
4. Grigorjewa N. Scientific-technological foundations of elastic automatic -modular of article. - Lutsk, „Nadstir'ya”, 2008. - 520 pp.
5. Kofman A. Introduction on applied combinatorial analysis. – Moscow: Nauka, 1975. 386 pp.