



International Journal of Innovative and Information Manufacturing Technologies, SHEI "Donetsk National Technical University"; 58, Artyoma Street, 83001 Donetsk, UKRAINE, Tel.: +38 062 305 01 04, Fax: +38 062 301 08 05, E-mail: tm@mech.dgtu.donetsk.ua, <http://iimt.donntu.edu.ua>

FEATURES OF ELECTROSTIMULATION OF TRUNK MUSCLES WITH S-SHAPED SCOLIOSIS

ROZORYNOV Georgiy

The Department "Systems of Information Security"; "State University of Telecommunications"; 7, Solomenskaya Street, 03680 Kiev, UKRAINE

Corresponding author: ROZORYNOV Georgiy, e-mail grozoryn@gmail.com

Submitted 09.11.2013; accepted 28.01.2014

Abstract. The basic requirements, produced to the electrostimulation apparatus, are considered. The economical mode of excitation of structures is determined during the leadthrough of electrostimulation. It is shown that it is necessary to take into account individual distinctions of electric excitability of muscles and the presence of the expressed asymmetry of its excitability. The asymmetry coefficients of electrical excitability of some muscles are determined. The block diagram of a specialized multichannel electrical stimulator "Polystim - 031" and its main technical characteristics are shown.

Keywords: electrostimulation, neuromuscular system, scoliosis, rheobase, chronaxie.

1. Introduction

Nowadays Ukraine has the best base of fundamental biomedical researches among East European countries which are important for creation of perspective electronic medical equipment. Demand for electromedical equipment is determined by its technical level, so the defining moment is to use the latest technological achievements in development, testing and production of samples of the latest technology. This is the key to increased competition in the biomedical industry, improving the quality of the equipment and reduce rapidly rising cost of health care.

Electrical stimulation is an area of research in which engineers, scientists and physicians get together in effort to use the property of the electrical excitability of nerve. These efforts result in devices based on modern technologies, which contribute to improving the lives of healthy people and people with disabilities.

Current electrostimulation devices are generally available in versions that provide special training of stuff to operate it. Non-optimality of criteria for selecting stimulus signal forces to increase the number of controlling items and unnecessarily expand the range of parameters of electrical stimulators, or, to simplify requirements for the devices instead. Therefore, one of the main requirements of the underlying principles of electrostimulation devices is strict control of threshold patterns of irritation of nerves when staff is able to use

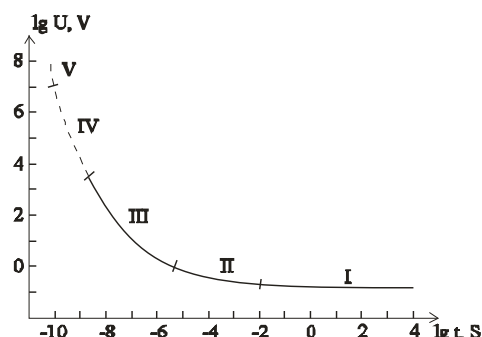

Fig. 1. Ranges of strength-duration curve

devices without any special training or by the patient himself.

2. Section contents

Relationship between the intensity of an electric stimulus and the time of its action on the excitable system is described by the Lapicque curve ("strength - duration"), which is usually divided into five ranges (Fig. 1). [1,2].

These ranges are different in forces and durations of the threshold electrical stimulus on several orders. Currently only the first three ranges are studied sufficiently, namely the proportion of latent periods of the nerve action potentials τ_{lat} in various areas of the curve, special features of the nerve behaviour from the

end of the stimulus before the reaction $\Delta\tau$, matching of durations, amplitudes, cycles and number of subliminal stimuli, causing threshold reaction while summation, ratio of action potentials in different ranges of the curve, polarization spaces of the stimulated area of tissue at different combinations of strength and duration of stimulating current, etc. Curve strength-duration is characterized by a number of indicators-constants:

- rheobase, or "long-term" threshold b (index of the first range);
- "short-term" threshold a (index of the third range);
- chronaxie τ (index of the second range);
- slope constant n (index of the third range);
- minimum energy that leads to the threshold response of tissue W_{min} (index of the second range);
- duration and amplitude of stimulation according to the mode of minimum energy t_{min}, U_{min} .

Usually not all the constants are used simultaneously, but some of them. The most common is measurement of rheobase and chronaxie. Biophysically and physiologically it is important to interpret the changes of these constants, linking them to changes in various physical and chemical processes in the excitable structure.

Consider the possibility of determining the most appropriate (economy) mode of structure excitation characterized by indicator W_{min} . The interpretation of this indicator is complex and requires further research, but it is possible to carry out a qualitative analysis. Normally, with a single threshold stimulation of excitable structure the curve strength-duration is described by Hoorveg - Weiss equation [3]:

$$U = \frac{a}{t} + b, \tag{1}$$

where U – stimulating intensity factor (for example, the potential difference that causes stimulating current), t – time of current action on tissue, which provides a threshold impulse, a, b – constants. Energy of threshold electrical stimulation is determined, as is known, from the equation

$$W = \frac{U^2}{R} t, \tag{2}$$

where R - total resistance of the circuit current flow. Substituting (1) into (2), we obtain:

$$W = \left(\frac{a^2}{t} + 2ab + b^2t \right) \cdot \frac{1}{R}. \tag{3}$$

In order to find the effective time of stimulating current, at which its energy is at its minimum, the first time derivative should be equaled to zero:

$$O = -\frac{a^2}{Rt^2} + \frac{b^2}{R}. \tag{4}$$

As a result we get a well-known expression for chronaxie:

$$t_{min} = \frac{a}{b} = \tau. \tag{5}$$

Now if we substitute the value of a (5) in equation (1), we obtain

$$U_{min} = 2b, \tag{6}$$

that means that the energy of the stimulating current is minimal when the minimum potential difference is equal to two rheobases.

Thus, from (5) and (6) the minimal energy is obtained from the expression

$$W_{min} = \frac{4ab}{R}. \tag{7}$$

Further we analyze the formula (3) in three time ranges of strength-duration curve.

At the first range (in continuous operation current) the term is $\frac{a^2}{t} \rightarrow 0$ can be neglected, and the term

$b^2t \rightarrow \infty$. At the second range equation (3) contains all the terms. At the third range the term is $b^2t \rightarrow 0$, and the term is $\frac{a^2}{t} \rightarrow \infty$. Graphically, it looks as shown in figure 2.

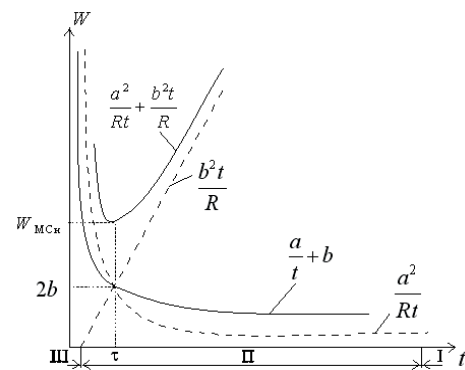

Fig. 2. Determination of the minimal energy of excitability of structures

It is easy to see that the region of minimal energy is within the second range.

The value of minimal energy is constant for a given excitable structure without changing its functional state. For motor nerves and muscles minimal energy level is

observed at long stimulus in the range 0.13 ... 0.28 mS.

Based on the principle of minimal energy, a number of electric stimulators with different performance and broad application were designed - from a stationary multi-channel device with advanced features to a

concave sides of the spine does not exclude its torsion, which leads to negative consequences caused by such electrical stimulation. This undesirable phenomenon can be eliminated by simultaneous synchronized excitation of transverse abdominal muscles (Fig. 3).

Table 1

Asymmetry coefficients of electrical excitability of muscles

Muscle name	$K_a = U_{conv} / U_{conc}$ at degree of scoliosis			Voltage of electrical stimulation, V	
	I	II	III	Concave side	Convex side
m. trapezius	1,11	1,18	1,25	$U_{conc} + 0,3U_{conc}$	$(U_{conc} + 0,3U_{conc}) \cdot K_a$
m. Latissimus dorai	1,10	1,35	1,41		
m. Longissimus dorai	1,04	1,33	1,40		
m. bliquus abdominis	1,11	1,34	1,35		

miniature device for individual use. Notable among them is the only one in Ukraine and CIS countries specialized electric stimulator "Polystim - 031", designed for prevention and treatment of scoliosis, flat foot, other disorders of the musculoskeletal system of children.

The current electrostimulation devices do not provide proportional terms of excitability of muscles on the convex and concave side of the spinal deformity. This ignores the fact of uneven reduction of the functional properties of muscles on the convex and concave side of the curvature of the spine, as they appear in different biomechanical conditions of work [4].

Pulled muscles on the convex side on an arbitrary reduction produce high-amplitude bioelectric signals compared to the contraction of muscles on the concave side. The extent of this asymmetry increases with spinal deformity. Consequently, during the electrical stimulation it is necessary to take into account individual differences in the electrical excitability of the muscles and especially the presence of evident asymmetry in excitability. The data on the asymmetry of the electrical excitability of muscles and different induction of muscle fibers in an excited state with scoliosis demonstrate the need of compliance with certain ratios of the intensities of stimulators while electric stimulation of functionally different muscle groups. In work [5], the following asymmetry coefficients K_a of electrical excitability of some muscles are defined and are listed in Table 1.

In Table 1 U_{conc} and U_{conv} - threshold voltages, causing excitation of muscles on concave and convex side of the spine are shown. From Table 1 it is clear that the required intensity of stimulating factor for the muscles of convex side is in K_a times greater than for the muscles of concave side. Nevertheless the mode of synchronous multichannel electrical stimulation has to be used. The excitation of muscles only on convex and

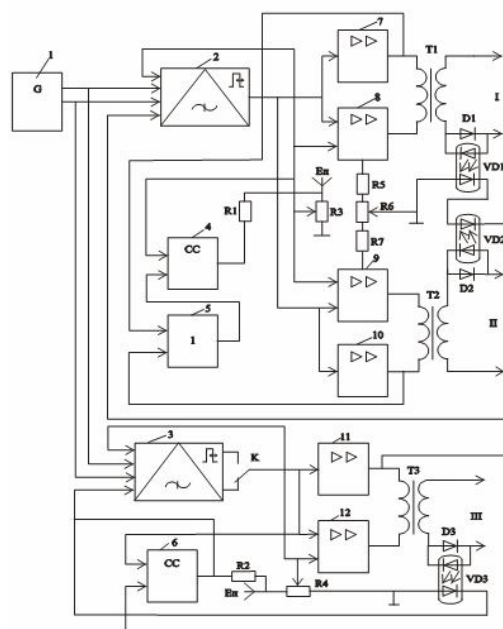

Fig. 3. Location of stimulation electrodes at treatment of scoliosis II-III degrees

All this was taken into account in development of a specialized electrical stimulator "Polystim - 031." The block diagram of the device is shown in figure 4.

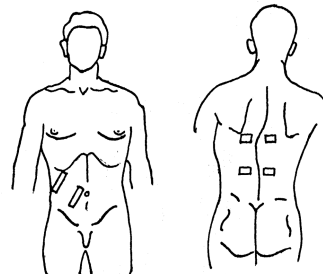

Fig. 4. Block diagram of multichannel electric stimulator

Electric stimulator contains function generator 1, that produces repetitive sets of linearly frequency modulated (LFM) signal of a rectangular shape. From the outputs of generator 1 LFM signals are sent to the signal inputs of the converters 2 and 3, where they are converted into a pulse width modulated (PWM) signals.

The use of two parallel operating transformers 2, 3 allows independent control of each other stimulus amplitude signals in the main interconnected (I and II) channels and sub channel (III) by changing the depth of PWM signals.

Table 2

Technical characteristics of electrostimulator

Characteristic	Value
Number of galvanically isolated channels	3
Pulse shape of the stimulating current	Asymmetric bipolar
Amplitude of the current in the load 1,5 kOm, <i>mA</i>	$(0...100) \pm 10\%$
Duration of stimulation pulses, <i>mS</i>	$0,2 \pm 20\%$
Variation range of stimulation rythm, <i>S</i>	$(1...20) \pm 5\%$
Ratio of excitation and relaxation periods	1:1
Variation frequency range of stimulation pulses at LFM and in the mode of continuous generation, <i>Hz</i> Built-in timer, <i>min</i>	$(10..140) \pm 10\%$ 10, 20, 40
Intensity control of the stimulating current	Light, sound
Supply voltage, <i>V</i>	$9 \pm 0,4$
Overall dimensions, <i>mm</i>	205 (w) × 55 (h) × 160 (d)
Weight, <i>kg</i>	1,5

The use of two parallel operating transformers 2, 3 allows independent control of each other stimulus amplitude signals in the main interconnected (I and II) channels and sub channel (III) by changing the depth of PWM signals.

In addition, the use of signal conversion of LFM into PWM, allows easy implantation of 7-12 trapezoidal law of the variation of the amplitude of stimulating signals while maintaining linear FM in areas of its rise and fall. This ensures high comfort procedure of electric stimulation. Amplifiers 8 and 9 are made with additional inputs, which include a chain of series-connected resistors R5-R7.

Changing the position of the engine of variable resistor R6 proportionally changes the ratio of coefficients of amplifiers 8, 9 at $\pm 30\%$ that reaches the required asymmetry of stimulating current in channels I and II.

Auxiliary channel III is different from the major ones with presence of direct and inverted outputs of the converter 3. This ensures the possibility of stimulation on band channel as synchronously with channels I and II so in the opposite to them.

Current pulses flow into electrodes through anti-parallel connected diodes D1-D3 and radiators photocouplers VD1-VD3. In the absence of signals in secondary coils of transformers T1-T3, for example, because of accidental disconnections or broken electrodes on control inputs of converters 2, 3 inhibit signal is installed formed with the help of coincidence circuits 4 and 6. Ban signal cancellation runs only after

connecting electrodes and reinstallation of the amplitude level from zero to the desired value by resistors R3 and R4. Main technical characteristics of multichannel electrostimulator are shown in Table 2.

Electric stimulator "Polystim-031" is compact, with a reduced number of adjustments, that makes it easier to work with and it can be used as well as in clinical practice as at home by the patient himself. Protection from overdose on time, from disconnection of electrodes and unauthorized installation of the amplitude of stimulating pulses make it one of the safest

devices. But of course its main advantage is high efficiency in prevention and treatment of scoliosis in early stages of its progression.

3. Conclusion

Introduction of new electronic equipment in medical practice, in particular, electric stimulation techniques is the most perspective and progressive in the field of non-pharmacological treatment and prevention of diseases of the neuromuscular system and the musculoskeletal system of human.

References

1. Gulyaev V.Yu., Matveev V.A., Oranskij I.E. E'lektrodiagnostika, e'lektrostimulyaciya i impul'snaya nizkochastotnaya e'lektroterapiya. Izd. 2-e. Ekaterinburg: Magnon, 2008.
2. Glushhuk S.F., Pekker Ya.S., Al' Kasasbex R.T. Malogabaritnyj avtonomnyj e'lektrostimulyator-zond. Medicinskaya texnika: Nauch.-texn. zhurn. 2011, 4, 34–39.
3. Vrbova Gerta, Hudlicka Olga. Centofanti Kristin Schaefer. Application of muscle/nerve stimulation in health and disease. London: Springer, 2008.
4. Civ'yan Ya.L., Aksenovich I.V. Mexanogenez e'ksperimental'nogo skolioza. Novosibirsk: Nauka, 1987.
5. Il'yasevich I.A., Shalatonina O.I., Shalatonin V.T. E'lektrostimulyaciya myshc tulovishha u detej, bol'nyx skoliozom. Metodicheskie rekomendacii Minzdrava BSSR. Belorusskij NII travmatologii i ortopedii. Minsk, 1981.