

FROM THE REVOLUTION IN COMMUNICATIONS AND COMPUTING TO THE REVOLUTION IN EDUCATION AND NATIONAL DEVELOPMENT



Prof. Alexander Anopriyenko

Donetsk National Technical University

UA-83000, Artema, 58, Ukraine

anoprien@cs.dgtu.donetsk.ua

<http://donntu.edu.ua>

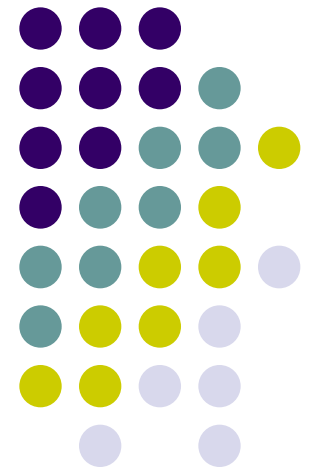

Covenant University
January 29-31, 2007



The plan of the lecture



- 1. Brief history of revolutions in communication and education**
- 2. The time of 3G GSM, mobile computing and Internet**
- 3. Preparing for Change**



Brief history of revolutions in communication and education



Modern revolution in communication has **a very deep roots:**

- **Most ancient revolution** in education was more than **20 thousand years ago**: it was invention of so called monologic and monocode in designing early mobile simulation tools (it is one of the themes for tomorrow lecture)
- **The second revolution** was the invention of **writing 5 thousand years ago**.
- **The third revolution** was **1 thousand years ago**: first universities was born on that time with libraries for students and teacher.

Brief history of revolutions in communication and education



4. **The fourth revolution** was the invention of **book printing 500 years ago.**
5. We have now **the fifth revolution:**
Internet + mobile computing

All these revolutions are the **various steps toward globalization and new quality of education**

Mobile Computing: Definitions



- *The use of a portable computer capable of wireless networking* (Forman, 1994)
- *A generic term describing your ability to use technology to wirelessly connect to and use centrally located information and/or application software through the application of small, portable, and wireless computing and communication devices* (Wikipedia)
- *Being able to use a computing device even when being mobile and therefore changing location. Portability is one aspect of mobile computing* (MobileMan)
- *A new paradigm of computing, in which users carrying portable devices have access to data and information services regardless of their physical location or movement behavior* (Jin Jing et. al, 1999)

Devices for Mobile Computing



Various:

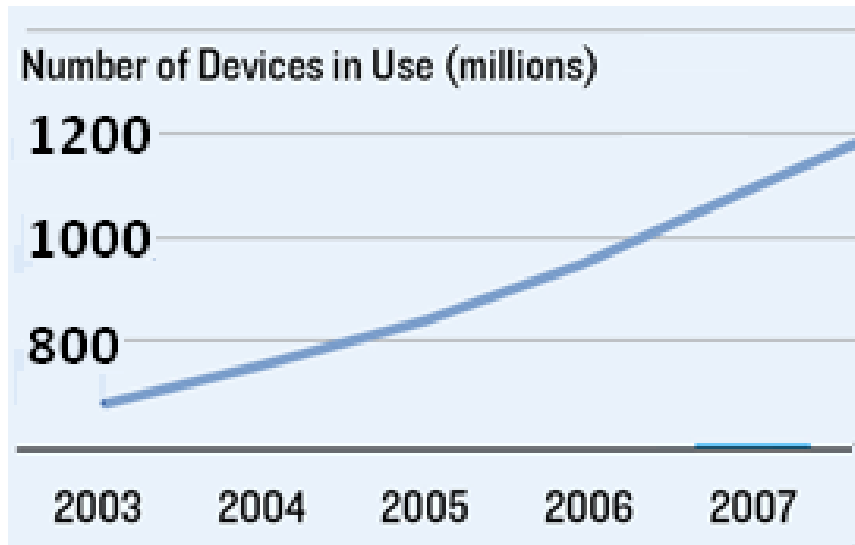



The Road to 3G

Evolution of mobile standards:

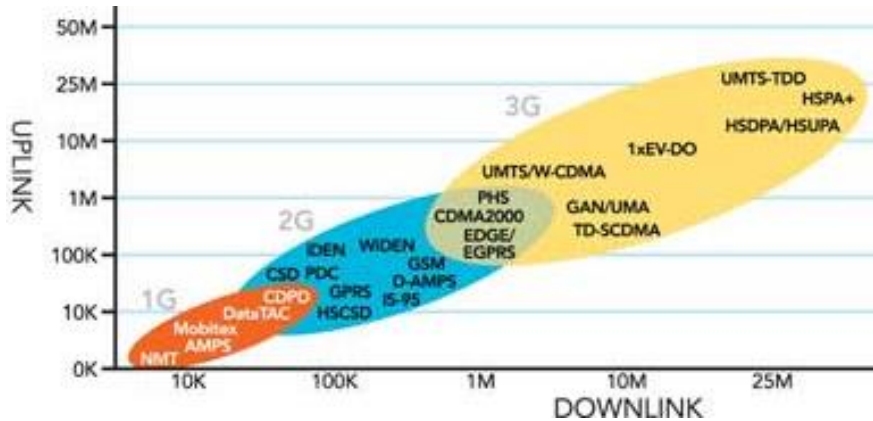

The Road to 3G

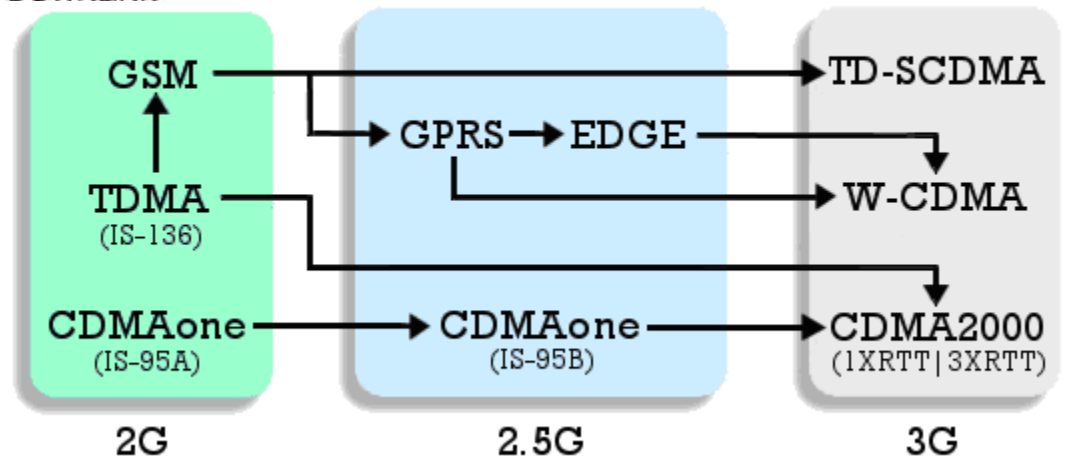

MODERN REVOLUTION IN COMMUNICATIONS: The Road to 3G



3G Standard was developed by International Telecommunication Union (ITU) and is called **IMT-2000** (International Mobile Telecommunications 2000).

Main goals:

- Global roaming
- New level of speed

Main Changes in Information Architectures



2000: predominately **server-centered** applications that integrated information processing and storage. Tightly coupled hardware and software for sensing, processing, and acting on information.

2006: emergence of **mobile-device-centered** applications, decoupled components for building new applications:

- Determine and display location and some content without contacting the server; database on mobile device
- Interoperable software components

Main Changes in Technologies



- **Platform independent programming**
 1. Java – byte code requires interpreter
 2. XML-HTML format representation of data
- **Platform independent operation systems (?)**
 1. Microsoft
 2. Unix/Linux

Now we have problems with compatibility of OS
Solution: Convergence?



The Evolution of “University Formula”



What is university in brief?

“Formula” – is the shortest answer:

From XI till XIX century:

Library + Peoples

The lecturer reads the book, and students listen





The Evolution of University Formula

From end XIX till end XX century:



1. **Library + Peoples**
2. **Equipment + Science and Practice**





The Evolution of University Formula

XXI century:



- 1. Library + Peoples**
- 2. Equipment + Science and Practice**
- 3. Internet + Innovations and scientific business initiative**

(based on modern communications, mobile computing and so on)

How Second Internet Revolution Change the World



Changes in traditional parts of modern university

New generation of Libraries: E-library!

On-line! Every library of the world for everybody!

Example: Google's Library Project: 1 million books now! (Normally Uni-library has 1-5 mln books)

Next future: 30 million books for all Internet's users!

Always with you! The whole library can be on mobile phone now!

Example: Electronic Bible on our mobile devices, supported by Java-applet

How Second Internet Revolution Change the World



Changes in traditional parts of modern university

New generation of Equipment: Computing!

On-line! Every computing device can communicate with each other and everybody through the Internet!

Example: Cisco Corporation: Millions devices for Internet communications worldwide are supervised and served from every engineering workplaces!

In result: world record of capitalization (600 billions \$)

Always with you! Your workplace are with you everywhere and in your hands



The Evolution of University Formula

XXI century:



1. **Library + Peoples**
2. **Equipment + Science and Practice**
3. **Internet + Innovations and scientific business initiative**

(based on modern communications, mobile computing and so on)

How Second Internet Revolution Will Change the World



New generation of innovations and scientific business initiative :

On-line! Everybody can now begin innovative E-business or/and M-business through the Internet!

New opportunities “E-business” for millions clients all over the world!

Always with you! Notebook or/and mobile phone are now main devices for worldwide innovative business!



Master's portal of DonNTU

- base for for educational and personal development for our students



Masters Portal of Donetsk National Technical University - Microsoft Internet Explorer

Address: http://masters.donntu.edu.us/index_e.html

Masters of Donetsk National Technical University

Ukrainian | Russian | English

DonNTU

Greetings and appeals
Rector Minaev A.A.
Vice-rector Bashkov E.A.
Associate Prof. A.Y.Anoprienko

Masters's Web-pages
 2000 - 2005 years

Masters's Gallery
 2000 - 2005 years

MASTERS'S PERSONAL PAGES 2000 - 2005 years
 (for navigation use numbers amount of pages on the right)

Faculty	2000	2001	2002	2003	2004	2005
Computer science faculty (FVTI)	20	20	32	34	30	67
Faculty of computer information technologies and automatics (FKITA)	8	24	20	36	46	69
Faculty of economy and management (FEM)	-	23	60	50	62	-
Mechanical faculty (MF)	16	12	15	17	13	28
Electrotechnical faculty (ELTF)	6	17	15	19	19	25
Faculty of ecology and chemical technologies (FEHT)	7	12	13	17	10	23
Faculty of energomechanics and automation (FEMA)	8	7	9	11	12	16
Faculty of geotechnologies and production managements (FGTU)	2	2	14	10	7	18
Phisical-metallurgical faculty (FMF)	-	-	18	12	29	30
Faculty of mining-geological (GGF)	8	13	13	18	12	25
English technical faculty (ATF)	-	-	-	5	-	-
Foreign masters	3	7	23	10	-	-
Total:	75	130	232	222	240	301

(3 items remaining) Downloading picture <http://c.bigmir.net/?s38404&t5&c1&d32&r1600...>

Internet

The Future is born in Universities

XXI century:

- **Library + Peoples**
 - **Equipment + Science and Practice**
 - **Internet + Innovations and scientific business initiative (based on modern communications, mobile computing and so on)**
- + Mental and intellectual potential!!!**

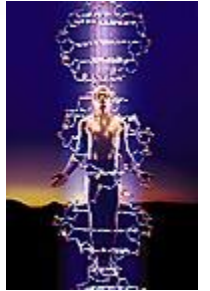



Master's portal of DonNTU - base for educational and personal development for our students



Links to sources and literature:

1. Anopriyenko A., John S., Al-Ababneh H. Simulation Tools and Services for Mobile Users: History, State-of-the-art and Future // Proceedings of the International Conference & Workshop on 3G GSM & Mobile Computing: An Emerging Growth Engine for National Development, 29-31 January, 2007. – College of Science and Technology, Covenant University, Canaan Land, Ota, Nigeria. 2007. P. 9-20.
2. Anopriyenko A., Bashkov E., Minaev A. University and Revolution in Communications and Computing: Experience of Donetsk National Technical University // Proceedings of the International Conference & Workshop on 3G GSM & Mobile Computing: An Emerging Growth Engine for National Development, 29-31 January, 2007. – College of Science and Technology, Covenant University, Canaan Land, Ota, Nigeria. 2007. P. 34-46.
3. Anopriyenko A., Ababneh Hasan, John Samuel Ndueso, Bandwidth usage maximization for enhancement of data exchange efficiency in TCP/IP-based networks // Informatics, Cybernetics and Computer Science (ICCS-2007). Scientific Papers of Donetsk National Technical University. Volume 8 (120). Donetsk, 2007. P. 331-339.
4. Minaev A., Bashkov E., Anopriyenko A. Master's Portal as the Practical Result of Studying Web-technologies // Proceedings of the International Conference on Engineering Education ICEE 2005 "Global Education Interlink", Silesian University of Technology. – Gliwice, 2005, Vol. I. S. 727-732.